

TRANSMISSION MEDIA AND METHODS OF KEYING

TRANSMISSION MEDIA

1. Several different media of transmission are used in the DCN and Single Service Telegraph Networks. The reference for these and their management is contained in JSP 321, however brief notes follow.

United Kingdom - Internal

2. In the UK rented landlines from British Telecom are used to internally connect Station Groups, and to connect such groups with external users. The lines, associated equipment and the services of BT engineers are rented by DNST. HMS INSKIP and HMS FOREST MOOR are situated on major nodes in the BT network and have resident BT engineers. In general dc lines are rented with the characteristics:

Operating Voltage ± 80 V dc
Bandwidth 3 kHz
Line Current 20 mA

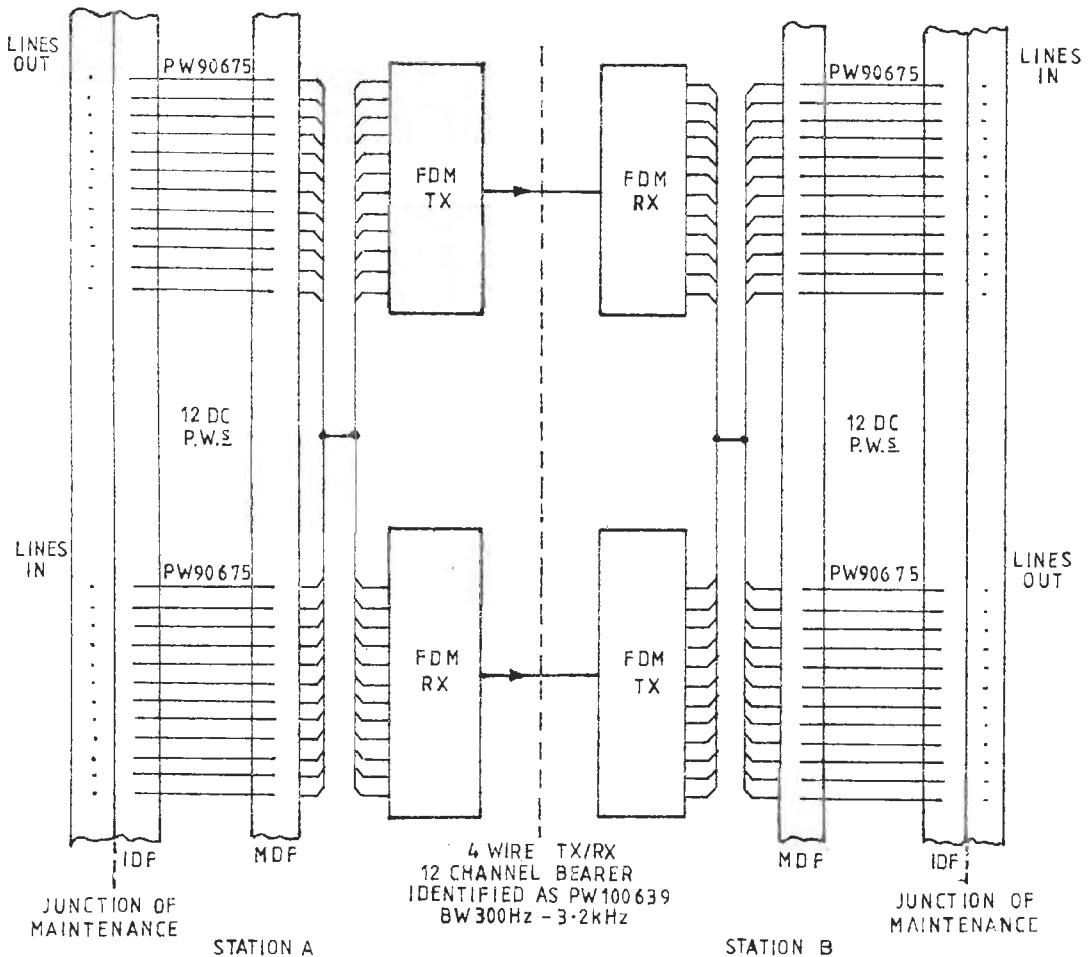

Figure 2.1

Line Characteristics

3. Within the UK, telegraph lines are provided by BT who allocate lines from the Defence Teleprinter Network (DTN) to meet the requirement specified by the sponsor. The DTN is a discrete network, controlled by BT, consisting of landline carriers, microwave and troposcatter links. Private Wires (PW) are allocated by BT according to availability, and routes are subject to change without notice.

4. To cater for the various communications methods in use, leased lines come in a number of standards. For point to point circuits, BT provide the following:

Schedule A - suitable for point to point speech.

Schedule B - suitable for speech and limited VFT use.

Schedule C - suitable for high quality speech, VFT and tone transmission with a maximum frequency not exceeding 3 kHz.

Schedule D - suitable for data transmission and other special purposes.

5. Any requirements which are more stringent than the parameters quoted must be stated at the time of ordering.

6. DC lines leased by DNST are to Schedule C standards.

Line Numbering

7. All leased lines are identified by unique numbers which are allocated as the line rental agreement is completed.

8. The line numbers depend on the type of line involved and the renter:

(1) DC and Audio lines are given a Private Wire number (PW). This relates to a particular duplex circuit between two stations.

(2) Data circuits are given a number D/xxx..... where xxx is a 2 or 3-letter code identifying the BT region from which the line has been rented, eg:

D/SD	-	South Downs (PORTSMOUTH)
D/LNW	-	LONDON NW (NORTHWOOD)
D/SCW	-	Scotland West (FASLANE)
D/PLY	-	Plymouth (PLYMOUTH)

Line Details

9. Details of all lines leased from BT are held on a data base by DNST at ESB. A printout is available for each station listing all leased lines terminating at that station. The printout will contain details of circuit terminations, characteristics and routes. The data base is updated by DNST as new leased lines are added or current leased lines are ceased. It is in the interest of all that Station Staff regularly check the validity of the station data held on the data base and forward corrections as required.

10. In general 2-wire systems are used (line and earth) with BT supplying 80 V for switching at the ITL. The BT earth is kept separate from the station earth to improve electronic security. A single PW is invariably used for transmission and reception legs of a 2-way circuit, hence if one leg is put out for repair the other leg will be lost.

11. All dc keying lines to CRIMOND (unmanned at night) are looped at CRIMOND so that the keystream can be monitored at the originating Commcen.

12. At the IDF the responsibility for the line is divided at a point known as the "junction of maintenance". This point divides BT responsibility from that of Station Staff.

Overseas - Internal

13. Landlines are mainly used to carry dc or audio. These are maintained by PSA or the Army to standards laid down in JSP 321 (usually more stringent than those for BT in UK). Some circuits are carried by microwave links, usually where the terrain is difficult or for reasons of security. These links are maintained by Army technicians.

Tropospheric Scatter Links

14. A Communication Link of up to 600 km may be provided by the use of UHF tropospheric scatter (around 900 MHz).

15. The Troposphere is in a constant state of turbulence which gives rise to local variation in the refractive index. These variations cause scattering of a wave passing through the turbulent area. The intensity of the scattered beam depends greatly on the angle through which it is deflected. The lower effective path is limited by the ground profile over the link, the upper by the increasing scatter angle, causing larger scatter attenuation. These limitations limit the horizontal spread. Thus there is for any path a limited volume of air which is effective for scattering, and the antenna beam width should in general be designed to cover this scattering volume. Aerials must obviously be of high gain and the scatter angle kept as small as possible. Beam widths are of the order of 1°.

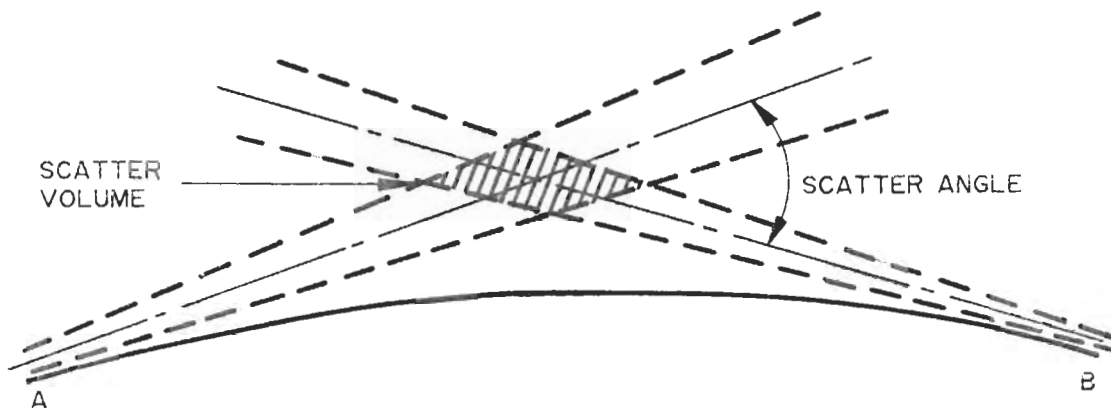

Figure 2.2

16. The fact that the received signal will contain components arriving with different amplitudes and phase relationships gives rise to distortion of modulated signals. Restriction of the scatter area by means of narrow beam aerials alleviates this. Reliability is further increased by use of four receivers and two transmitters giving quadruple space/polarity diversity giving up to 99.9% availability.

17. An example of such a system is installed at GIBRALTAR for the NATO service with LISBON at 905 and 840 MHz. Six traffic channels are provided, each capable of voice, or sub-division into 6 v.f. telegraph channels, plus an engineering channel (Voice or RATT).

18. Both NATO and Civilian North Sea Oil Rig Communications rely heavily on Troposcatter Links. DCN circuits UK → GERMANY and UK → NI are also via troposcatter.

Long Haul Communications

19. Communications between fixed sites at home and abroad, or between fixed sites and mobiles (eg ships) are achieved by three methods, other than tropospheric scatter, described earlier. Each method involves different engineering practice, and often one method is used as a standby for one of the others.

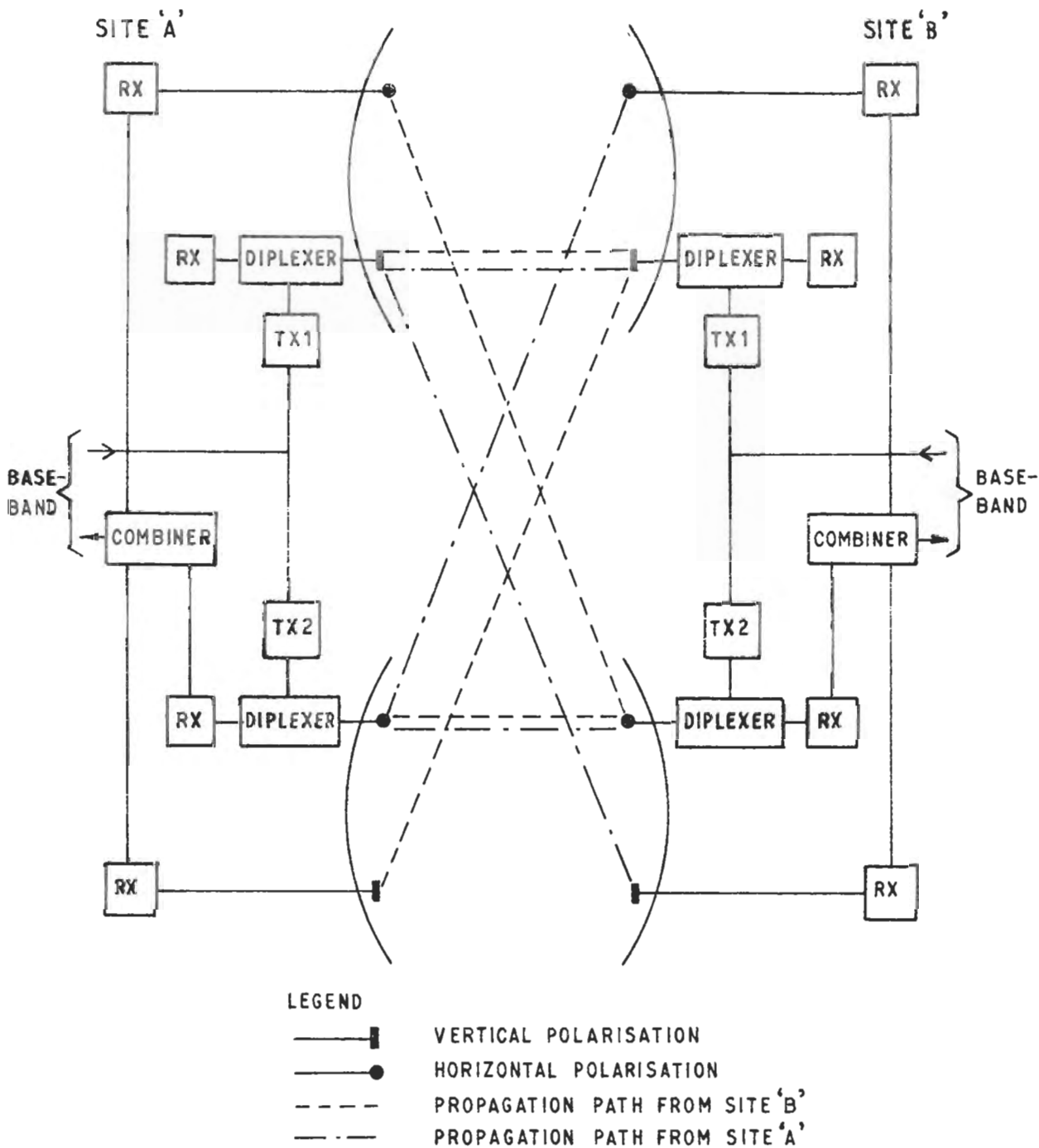
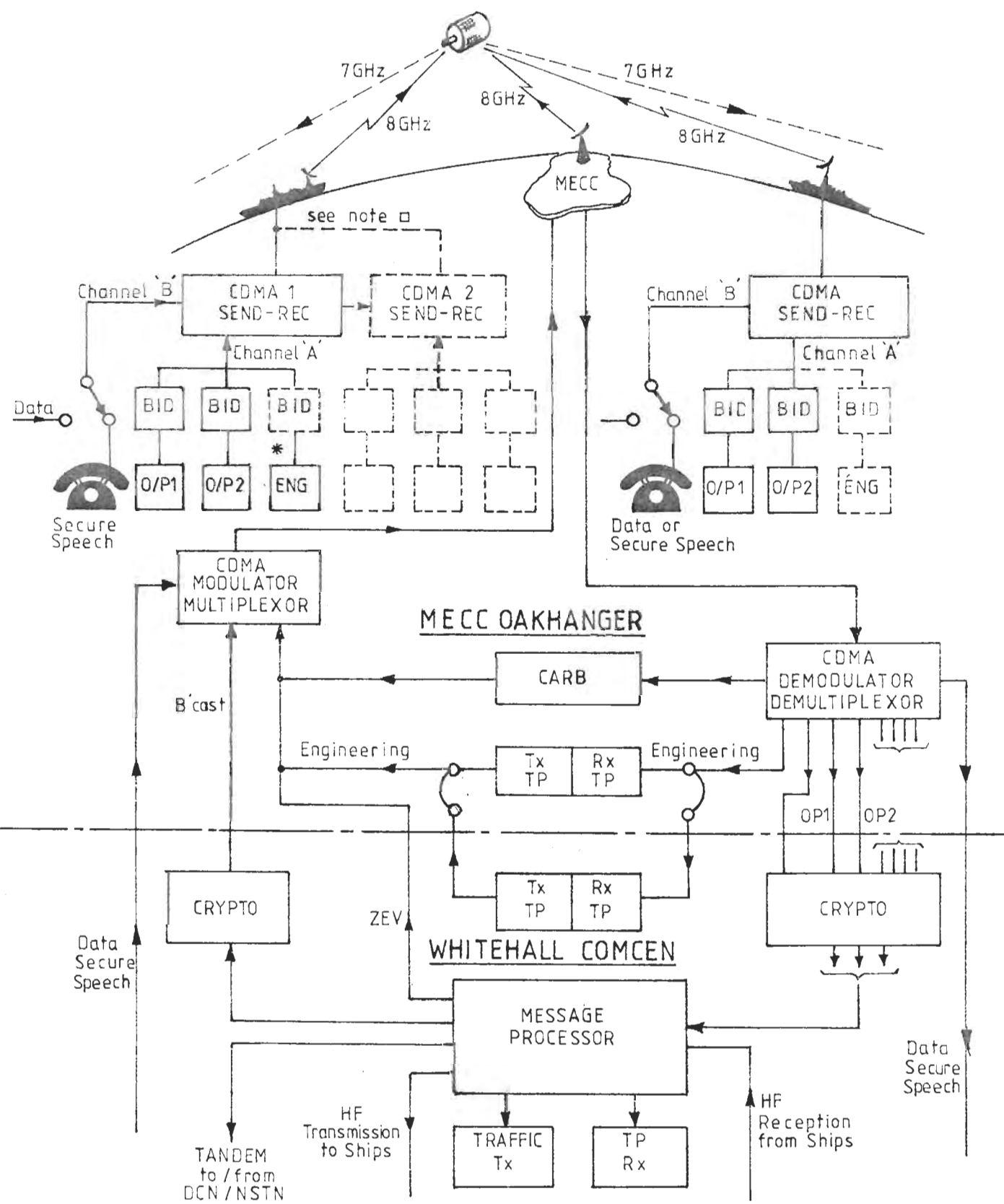

Figure 2.3 - Tropospheric Scatter System Block Diagram



NOTE:- * Future Planned Engineering Crypto.
 □ Additional CDMA's in Parallel, enhances Traffic capability.

Figure 2.4a - Basic Satcom Signal Flow (RN)

Satellite Communications

20. Long range wide-band communications links are regularly provided by Satcoms resulting in consistently higher standards of reliability, capacity and security than those achieved by HF propagation. These improvements must however be balanced against cost of the service and the possible ease of neutralisation due to attacks on the space segment of the system.

21. Within the UK military communication system, satellite communications make extensive use of the Skynet 4 system. Interoperability agreements allow UK Satcom users to utilise both the American DSCS and NATO satellites if required, eg in the event of National satellite failure, though the capacity for sharing space facilities is limited.

22. All military satellite accesses for UK forces are arranged by CDCN.

23. The primary UK military SHF earth station is RAF OAKHANGER with limited fallback facilities at RSRE DEFFORD, with the RAF operating and managing the space segment and the fixed satellite ground terminals (SGTs). Both of these stations are connected by landline to major shore headquarters for the transfer of data, voice and telegraph information.

24. UHF Satcom is controlled by UKSUBCAMS.

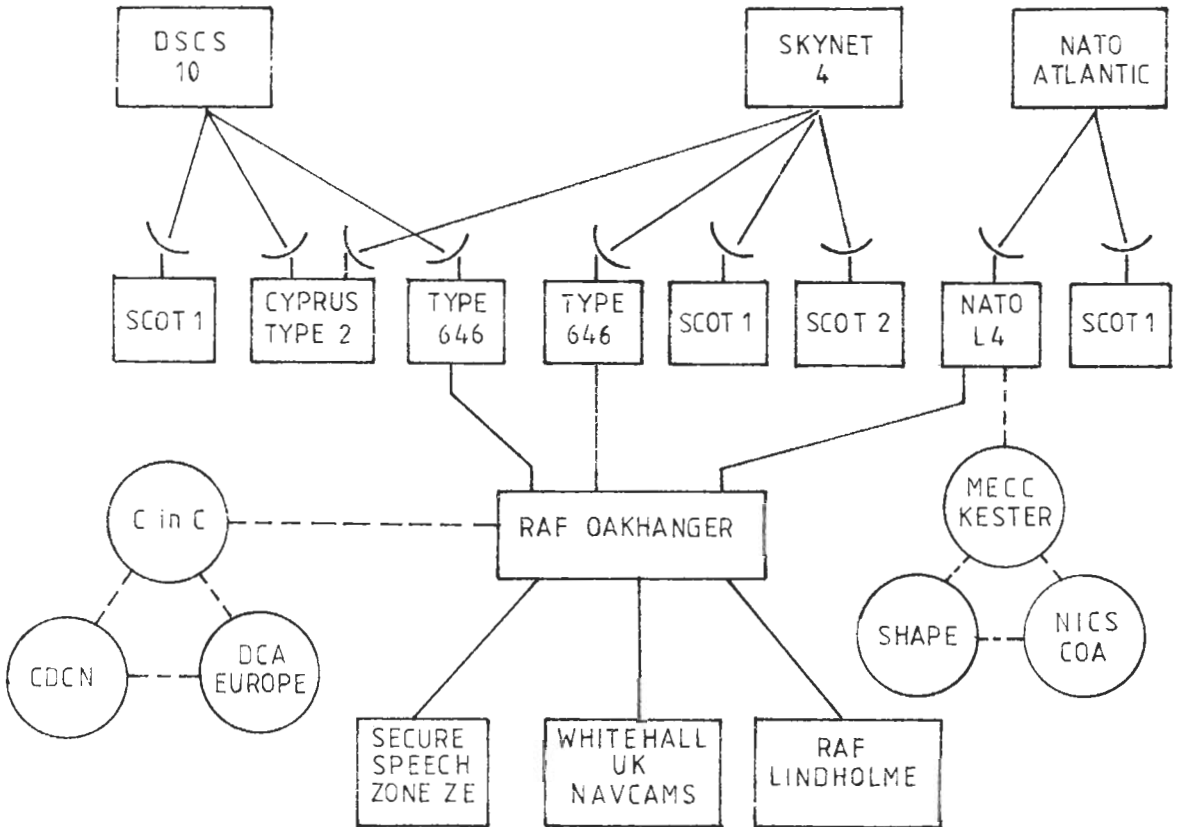

Figure 2.4b - Allied Military Satellite Communication System

Landline

25. Some overseas circuits are connected by Landline (eg CANBERRA). These circuits are ordered through BT who liaise with other international networks as necessary. Though called line circuits they are actually processed by the authorities in their own way, ie CANBERRA circuit travels overland via the POST OFFICE TOWER and microwave links to GOONHILLY, then by commercial satellite to HONG KONG. The last leg being by submarine cable to the West Coast of Australia and microwave links to CANBERRA.
26. As long as the line parameters are met it is not our concern how BT processes the signal. As landlines are single-routes, most have alternative circuits which may be raised in the event of failure. (eg CAN traffic diverted to the HONG KONG service, then an HF link established from HONG KONG to CANBERRA.)
27. Landline route reliability is generally very high. They are connected to the MDF and IDF in a similar manner to National Lines. Extra lines are often required for Exercises or Operation, to key rented transmitter suites (ie Ascension or Bahamas). Negotiations for these extra requirements are initiated by DNST. These circuits are engineered by TELEX.

LF and HF Propagation

28. The majority of DCN and RN Fleet Ship/Shore/Ship communications is still by HF radio, with the addition of LF components of Fleet Broadcasts and VLF Submarine Broadcasts. DCN frequencies are listed under the appropriate title in DCNP 3, whilst all frequencies registered for RN use are listed in RNCP 5. All major stations also carry copies of the International Frequency Register which lists every frequency registered throughout the world and details of user and registrations.
29. The anomalies and problems concerned with HF propagation are well known and are summarised at Annex A. However HF path prediction is becoming more reliable with new methods of ionospheric sounding and several aids are available to HF Engineering Centres.
30. Commercially produced (by MARCONI) HF prediction tables are sometimes available in HFECs and are in general very detailed.

NAVMUF (RNCP 1 - Fleet Addendum)

31. A Hewlett-Packard HP 41 CV calculator and accessories issued to the Fleet, and certain HFECs to aid HF path prediction between any two points on the earth's surface. It will calculate path length, MUF, OMF for two stations taking into account the daily measure of solar radio noise, sunspot activity (IF2) as broadcast by WHITEHALL on all HF and satellite broadcasts and all activated MRLs and SRLs. RNCP 1 gives details on manning the program. This device is useful for calculating HF predictions.

Chirpsounder (Outfit AN/TRQ 35(V))

32. The Tactical Frequency Management System (Chirpsounder) is a commercial real-time oblique ionospheric sounding system which measures the terminal to terminal HF Radio Path characteristics of a communication system.

33. The system comprises a Transmitter, Receiver, Spectrum Monitor and associated adaptors to measure, in real-time, the propagation and noise conditions affecting a particular HF frequency.

34. The system transmits a low power FM CW test signal over the required communications path using either the same antenna as the primary bearer or a dedicated omni-directional antenna. The test signal sweeps through the entire HF band and is tracked by a time synchronised Chirpsounder receiver. Each sweep is completed in 4 minutes 40 seconds and is repeated at 5 or 15 minute intervals. To avoid interference, each transmitter is allocated a Clock Time and a Start Time to identify the specific timing of the transmission. eg INSKIP has a Start Time of 01 minute 38 seconds and a Clock Time of every 5 minutes.

35. Transmitters are sited ashore, ie INSKIP, GIBRALTAR, ASCENSION ISLAND plus those operated by other owners (American), any of which may be selected providing the start delay is known. Receivers are located at certain shore locations (ie FMR) plus certain selected ships. Installation is simple, the equipment being portable requiring only aerial and power supplies.

36. DCNP 10, the Chirpsounder Directory, lists all known Chirpsounder stations giving Position, Start Time, Clock Time and Authority controlling Chirpsounder transmitters.

37. The receiver incorporates a display (Fig 2.5).

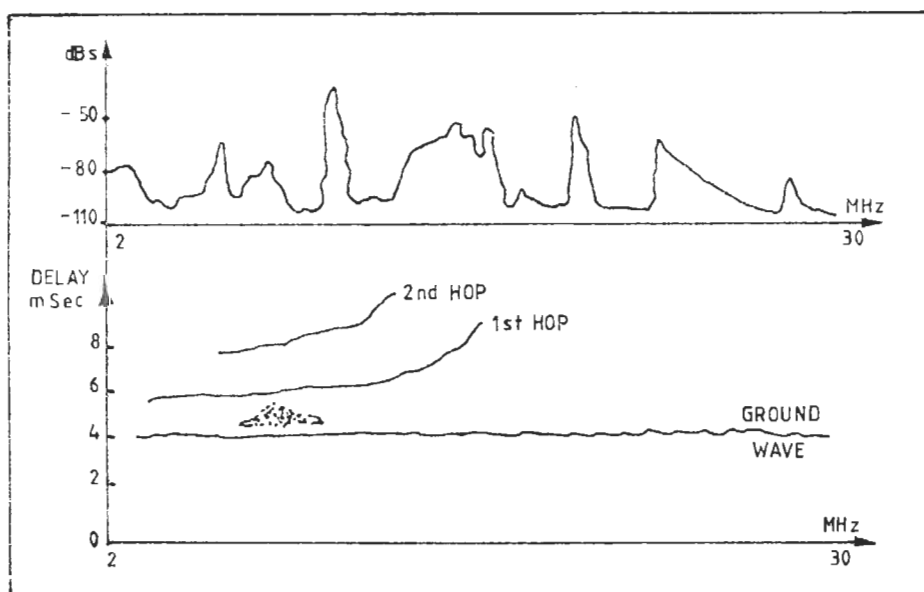

Figure 2.5

The upper display gives an indication of signal strength against frequency. This is total strength combining all paths and random signals present. The lower display shows relative time delay against frequency. Time delay is proportionate to path length, hence modes which travel the shortest path will have the shortest time delay, ie the Surface Wave. The next delayed component will be from the single-hop path and so on with multi-hop transmission paths. Each receiver has three channels, hence may be pre-tuned to three transmitters.

38. From the display the best frequency may easily be chosen, ie strong received signals with preferably a single-path to combat multipath fading. Use of this system on trial allowed ZBZ 5 communication between UK and GIBRALTAR at a power output of only a few watts.

39. A Spectrum Monitor may be added at the Receive site. This displays, in Histogram form, channel occupancy during the previous 30 minutes across the swept band. Both Receiver and Spectrum monitor displays may be expanded in frequency as required.

40. An enhancement to the system is the addition of Transmit and Receive adaptors. This enables a 38-character message to modulate the transmitter up to 63 times each sweep. Should any radio path exist between the two stations this message will get through, an obvious aid to circuit engineering.

METHODS OF KEYING

41. Excluding Satcoms, types of modulation found in Shore Telecommunication are fairly standard, and are summarised below. Telegraphy today is mainly automatic, involving automatic message switches (TARE/AMRAD/OPCON/MEP), consequently codes used must precisely match the requirements of these devices.

Murray Code

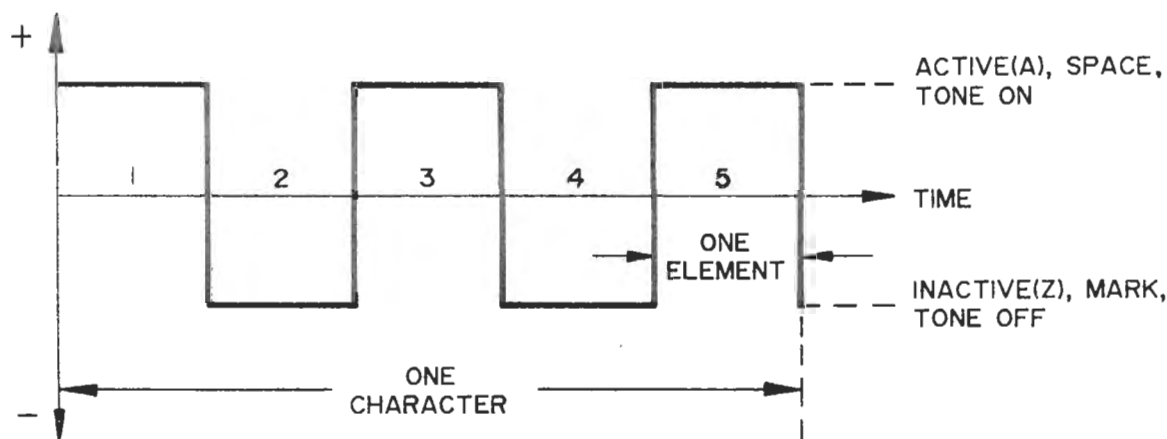

42. Each character is of equal length and consists of five elements (or bits). Each element can be a Mark or a Space, thus giving 2^5 or 32 possible combinations, ie:

- 26 letters/figures and punctuation
- Letter shift
- Figure shift
- Carriage return
- Line feed
- Space
- All Space (used in tape preparation)

43. Because all elements are of equal length and each character contains a random number of marks and spaces, it is virtually impossible to distinguish individual characters in a stream of Murray Code bits. In addition the two terminal equipment speeds would have to be synchronised with each other. Consequently this is known as a **SYNCHRONOUS code** and is unfit in its present form for use in a system. It does however form the basis of the $7\frac{1}{2}$ unit code.

$7\frac{1}{2}$ Unit Stop/Start Code

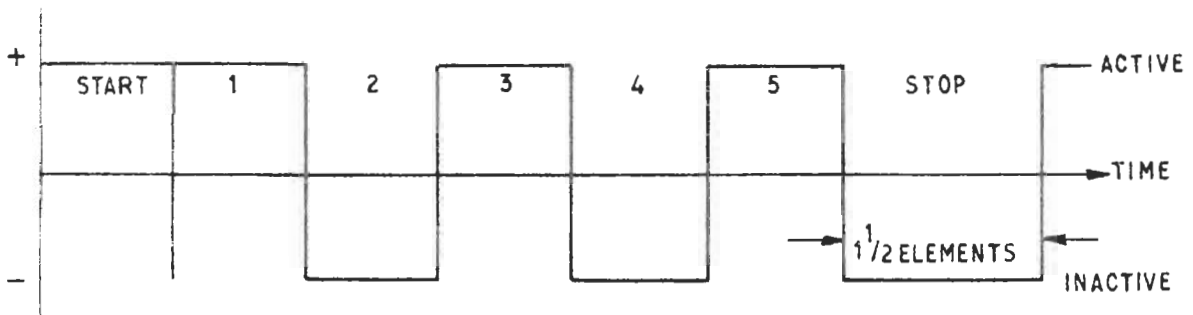

Figure 2.7

44. In order to synchronise the send and receive teleprinters each character of the 5 unit code is preceded by a start signal (ACTIVE) of one element and followed by a stop signal (INACTIVE) of one and half elements. (ie ACTIVE commences teleprinter or autohead action and INACTIVE completes it.) The extra half element allowing each character to be recognised.

Protected Codes

45. The Murray Code is UNPROTECTED, mutilation of one element will result in an incorrect character being printed. This error cannot be detected electronically as all combinations of elements are in use. In a PROTECTED code, mutilation of a code element causes a REDUNDANT character to be produced. This will be seen as an error and not printed. The most common code containing redundancy used with DCN circuits is the 7 unit Synchronous Van Duuran Code.

Van Duraan Code

46. This code is used on fixed DCN services where a high degree of accuracy is required (by automatic message switches). Seven units of equal length are used, giving a possible 128 combinations. Of these, 35 have three Marks and four Spaces. These are the only combinations of element which are used, ie:

- 31 Characters as Murray Code
 - 1 Idle Alpha (permanent Active)
 - 1 Idle Beta (permanent Inactive)
 - 1 RQ (Request for Repeat)
 - 1 Spare

47. At the receive end a simple device counts the number of marks (Inactive elements) in each group. If the number is not three, an error is indicated which may be a pure alarm (bell, error symbol, inhibition of further printing) or it may initiate automatically a sequence of events to correct the message - known as the ARQ cycle.

48. There is no requirement to introduce start and stop elements into the 7 unit code as it is a synchronous code, having the advantages over the 5 unit code of:

- (1) Redundancy is introduced, thereby enabling error detection and correction (EDC).
- (2) It is synchronous, requiring no Stop/Start elements.
- (3) Three extra facilities are available over the 32 of the 5 unit code.

A double inversion in one character would not be detected, but this occurrence is rare.

Telegraphic Speed

49. **Measured** in BAUDS. The BAUD speed of a signal is defined as the number of the shortest elements which can be transmitted in one second.

- eg 20 msec element - 50 Bds
- 13.3 msec element - 75 Bds

As the standard word length is five letters and a space this corresponds to a word speed of $66\frac{2}{3}$ and 100 wpm respectively.

BAUD Speeds in use are:

- 100 Bds - Some Broadcasts
- 50 Bds - Engineering - some MRLs
- 75 Bds - Ship-Shore, Broadcasts, some DCN circuits
- 96 Bds - DCN TDM 2-channel with EDC

41.2 Bds)	Some Crypto
61.1 Bds)	
45.5 Bds		USA

Slower BAUD speeds are sometimes found in submarine communications - right down to 1 BAUD.

50. Synchronous data services and digital speech signals have speeds rated in bits per second, which may be considered as equivalent to BAUDS. Such speeds are normally at kilobits per second (kbps) rates and include the following:

NSTN trunks	9.6 kbps
NSTN local access	9.6 or 4.8 kbps
Satcom Secure Speech	2.4 kbps
KILOSTREAM	64 kbps
MEGASTREAM	2.048 Mbps

Telegraphic Distortion

51. The telegraphic signal will in general always arrive at the receiving terminal with some form of distortion in its form. For example elements may be of unequal length and/or mutilated by noise. Distortion in a telegraph signal is defined as "The displacement in time of the signal transitions (Z to A or A to Z) from their true positions".

52. Distortion is expressed as a percentage and is always measured at the transition which is displaced by the greatest amount. It is calculated thus:

$$\% \text{ Distortion} = \frac{\text{Displacement (msec)}}{\text{Element length (msec)}} \times 100$$

However in practice it is measured directly on a Telegraph and Data Signal Analyser (Annex B). This device gives a direct percentage distortion reading.

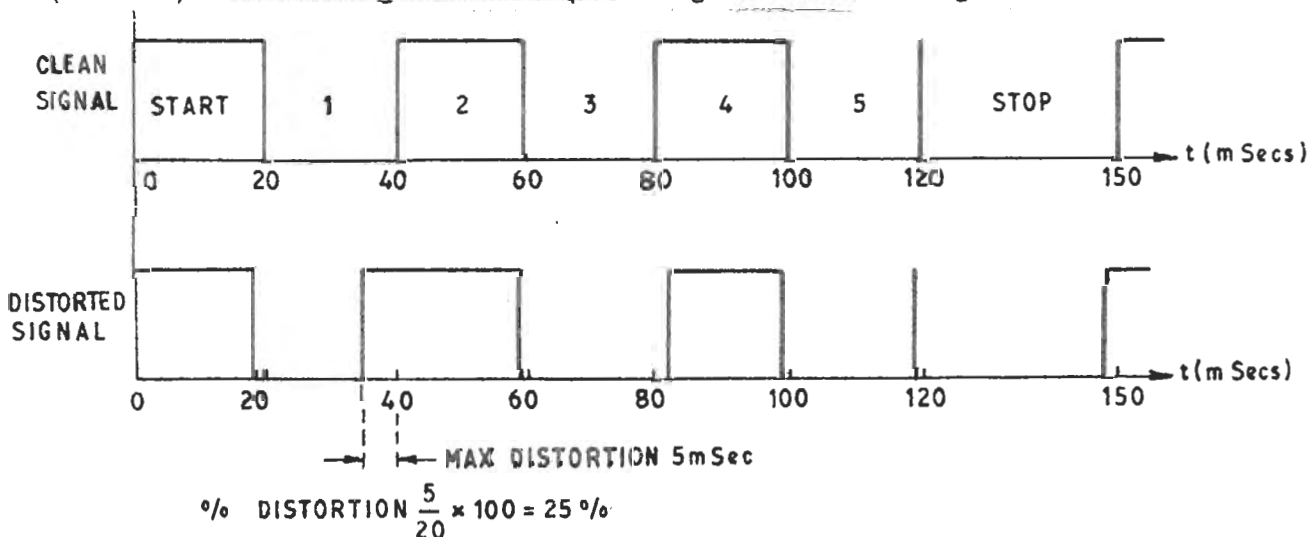

Figure 2.8

53. At the receiving terminal the telegraph signal is processed in some way. It will be passed to a security box for decryption or to a teleprinter/tape punch if in plain language. All of these devices sample the elements of the signal for a given period, usually in the centre of each element. Consequently the amount of distortion in a telegraph signal which may be tolerated and still provide acceptable page copy depends on this sampling period.

eg: Suppose a sampling period of 1 msec.

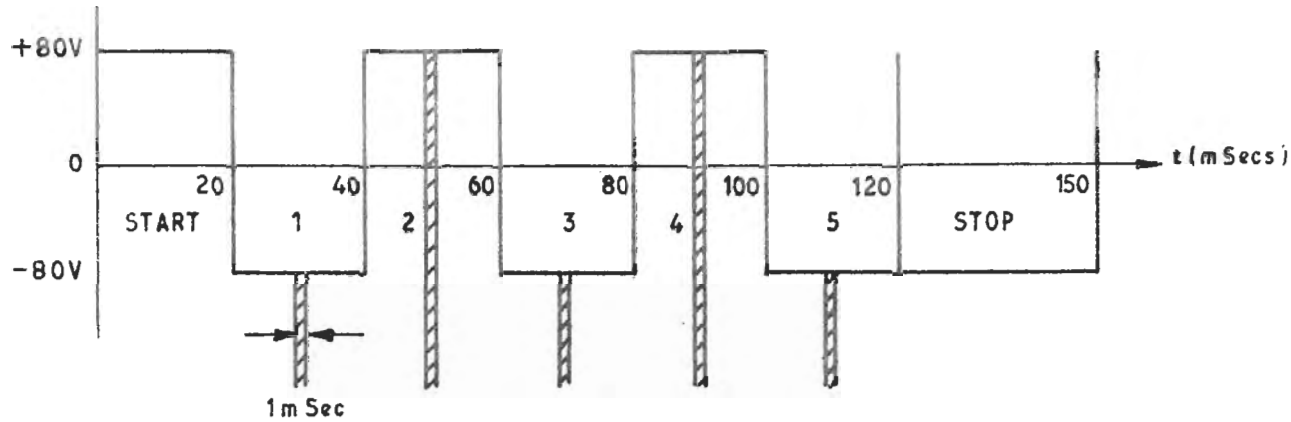

Figure 2.9

It can be seen that any distortion in the 9.5 msec areas each side of the sampling area will have no effect. The machine therefore has a MARGIN to cope with telegraphic distortion up to:

$$\frac{9.5}{20} \times 100 = 47.5\%$$

This figure would be quoted as the MARGIN of the machine. (TGN sampling period 2.5 μ sec.)

54. Modern CRYPTO and EDC equipments employing electronic sampling often have margins of 49%. The disadvantage of such short sampling periods is the possibility of sampling during a noise peak, producing an error character.

55. There can be many causes of distortion, though using modern electronic terminal equipment, involving few mechanical processes, it is most likely caused by the media through which the signal has to pass. As will be seen later many precautions are taken to ensure a "clean" signal is received. Satellite and cable circuits usually suffer from very little distortion (4-8%). Radio (HF and LF) circuits are much more prone; the signal often becoming unusable, though careful system engineering can improve reception remarkably.

Fortuitous Distortion

56. The random displacement, splitting or disruption of elements in a character.

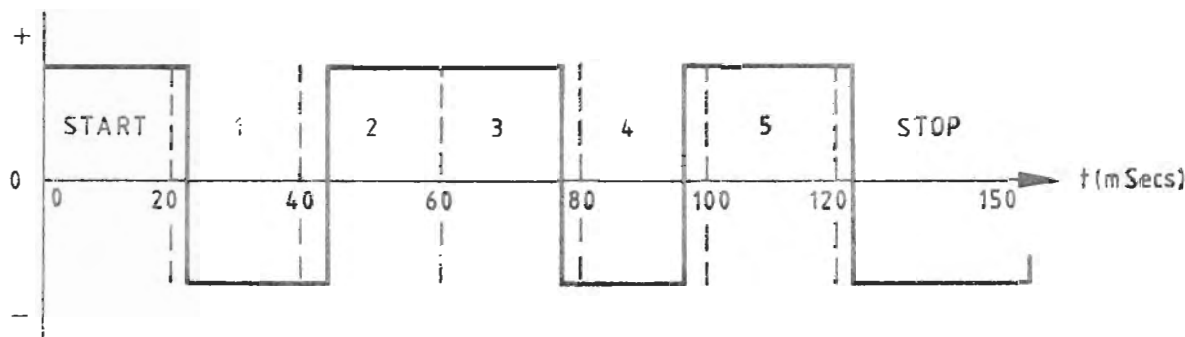

Figure 2.10

This is by far the most common type of distortion very prevalent in Radio circuits. It is the most serious variety due to difficulty in isolating the causes. The main causes being:

- (1) Poor propagation conditions.
- (2) Induction from adjacent cables.
- (3) Poor earth connections, faulty plugs etc.

Speed Distortion

57. Caused by a speed difference between send and receive machines.

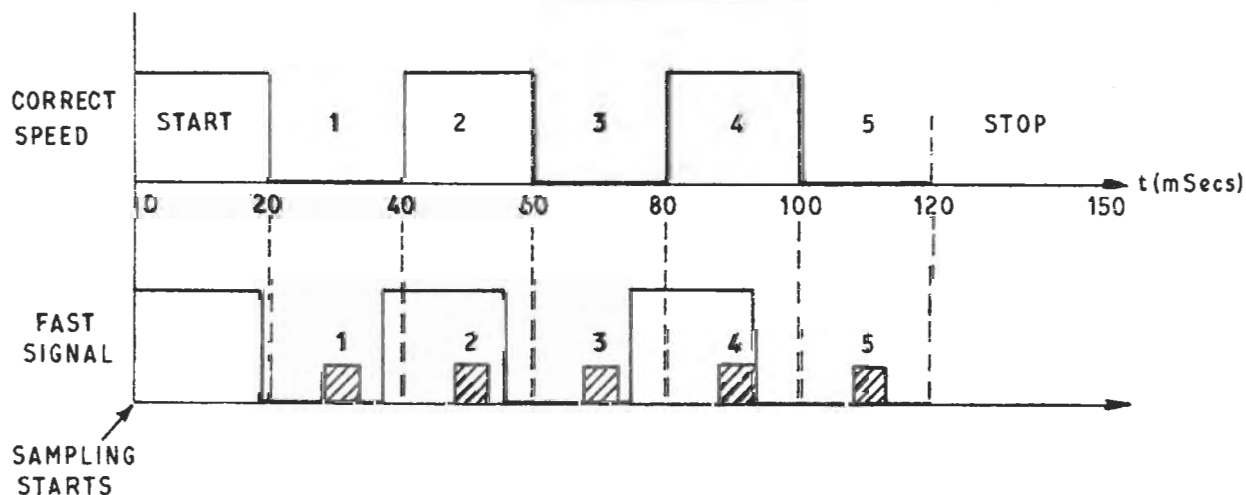

Figure 2.11

Characteristic Distortion

59. Repetitive Splitting or disruption of specific elements in a character.

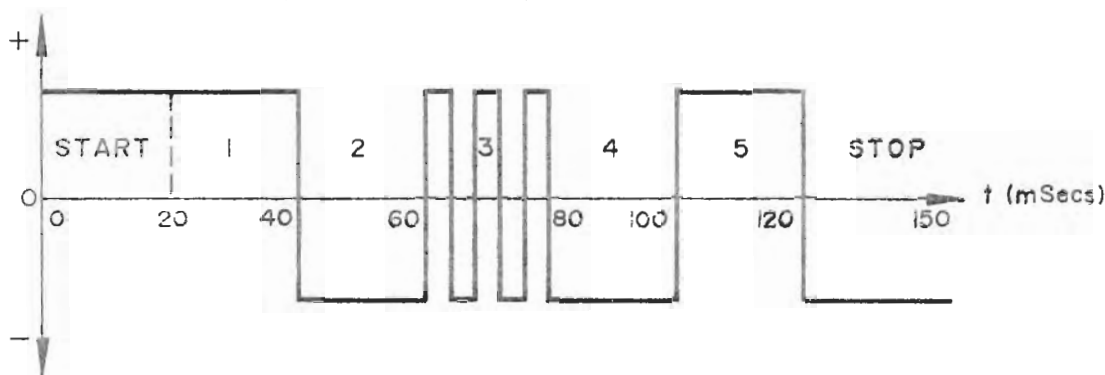

Figure 2.13

All characters are not necessarily affected, **although** when the distortion occurs it is always associated with the same element. Generally a "send" equipment defect, usually the ITL.

60. **Acceptable limits for line distortion** are published in JSP 321. Distortion occurring over a Radio Path (DCN HF fixed service, MRL, CRL etc) cannot conform to set limits and is in general a subject of real-time engineering to keep at a minimum, though a knowledge of receive telegraph equipment margins enables corrective engineering to take place before the signal goes corrupt. This is extremely important when operating into Automatic Message Handling equipment.

MODES OF EMISSION

61. The **allocation** of frequency is, as seen earlier, the responsibility of the International Frequency Registration Board (GENEVA), with the HOME OFFICE acting as our agent. The IFRB assign a frequency and a bandwidth.

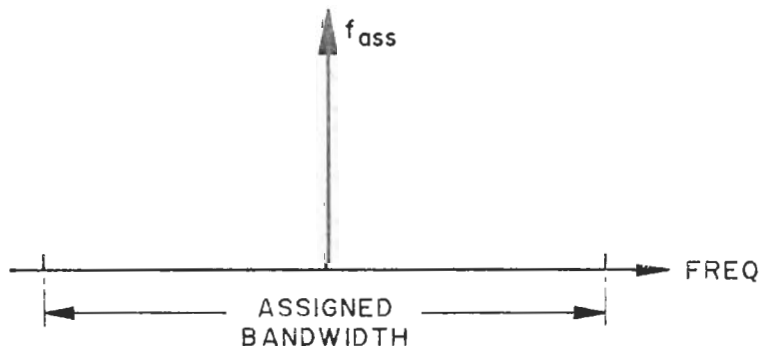

Figure 2.14

- (1) The ASSIGNED BANDWIDTH must contain 99.9% of the radiated power.
- (2) The ASSIGNED FREQUENCY must be the centre frequency of the assigned bandwidth.

Emission Designators (Annex C, BR 222)

62. In order to accurately describe a particular radio emission, a system of emission designators has been devised, and recently updated (1.1.82). It is recognised by international convention and used world-wide. Additionally in the Service we use a further designator which includes BAUD SPEED and ARRANGEMENT. This is used as a communications designator throughout Naval Communications Publications and is in common use. For example the parameters of the HF component of the UK Primary Ship Broadcast B11A are described:

J2B	/	850	/	1	/	75	ie
Abbreviated Emission Designator		Shift (Hz)		Arrangement		Baud Speed	

63. We are in general concerned with three types of emission: CW, RATT and VOICE at HF and LF. Satellite Communications utilise RATT and other techniques for voice which will be discussed in the SCOT module. In general amplitude modulation is used at HF and LF. Should ELF be used in the future for Submarine Communications it is likely that Phase Reverse Keying will be used (PRK).

64. It will be noted from the references on emission designators that consideration is now given to the method of generating the signal. The output wave however may be identical for two different designators, ie:

J2B - produced by amplitude modulation ($f_c + f_m$ and $f_c - f_m$ - unwanted sideband removed by filter) - Ship System.

F2B - an identical signal produced by pulling a VCO - strictly frequency modulation (TSK - TDZ). When liaising with HMS INSKIP always quote the assigned frequency and parameters. INSKIP will calculate and apply any offset required for single sideband radiation.

Continuous Wave (CW) AIA

65. One frequency from a transmitter is switched on and off in response to the operation of a morse key.

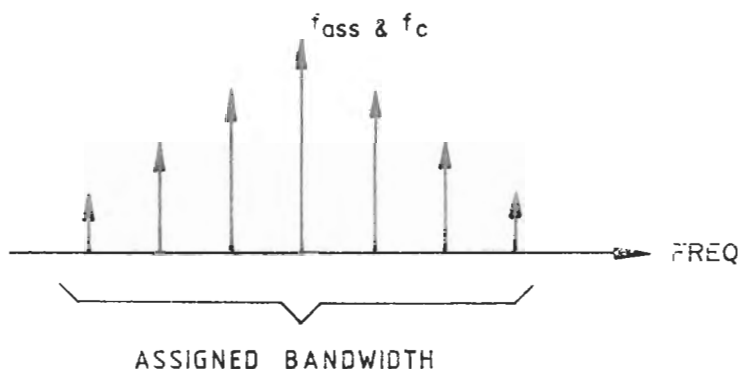

Figure 2.15

Where f_c is the frequency to which the transmitter is tuned. The transmitter radiates when the key is pressed. At 25 wpm (standard word PARIS + SPACE) the keying speed is of the order of 15 Hz. This will therefore produce harmonics related to the keying speed. It is normally acceptable to include up to the third harmonic to preserve signal shape. Consequently a bandwidth of $6 \times 15 \approx 100$ Hz is required.

66. CW can be arranged such that the carrier is normally on, but turned off when the key is pressed. This is known as "Interrupted Carrier Keying" (ICK). This mode has several engineering advantages but is difficult to read. It is not in general use. CW uses:

- (1) CW Broadcasts (Secondary Broadcasts).
- (2) Ship/Shore.
- (3) Submarine Broadcast.
- (4) Frequency Availability Broadcast.
- (5) "Last Ditch".
- (6) Some ICLs.

67. Usually known as RATT (Radio Automatic Teletype). One frequency is transmitted for the active condition and another for the inactive, ie only one frequency is transmitted at any instant in time.

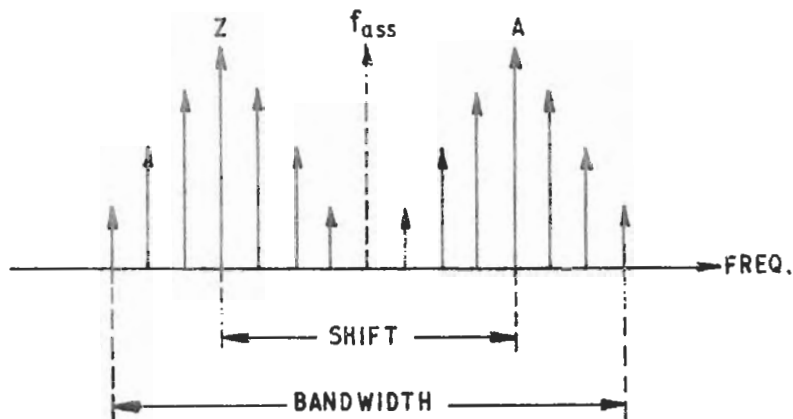

Figure 2.16

SHIFT - The difference between the two tone frequencies.

- ARRANGEMENT - Highest frequency ACTIVE - ARRANGEMENT 1.
 - Lowest frequency ACTIVE - ARRANGEMENT 2.

Once again harmonics of the keying frequency (BAUD SPEED) must be included in the bandwidth to preserve signal shape. At 50 BAUDS, signal keying speed is 25 Hz. Thus to include up to the third harmonic the bandwidth must be:

$$\begin{aligned} & \text{SHIFT} + 6 f_o. \\ = & \text{SHIFT} + (3 \times \text{BAUD SPEED}) \end{aligned}$$

or for 850 Hz shift at 50 BAUDS = 1 kHz.

68. The dc telegraph signal is used to produce two audio tones, usually 1275 and 2125 Hz. These tones are used to modulate a single sideband suppressed carrier transmitter. In order that the two tones are equally spaced about the assigned frequency the transmitter is offset in frequency. The amount of offset being equal to the centre frequency of the two tones.

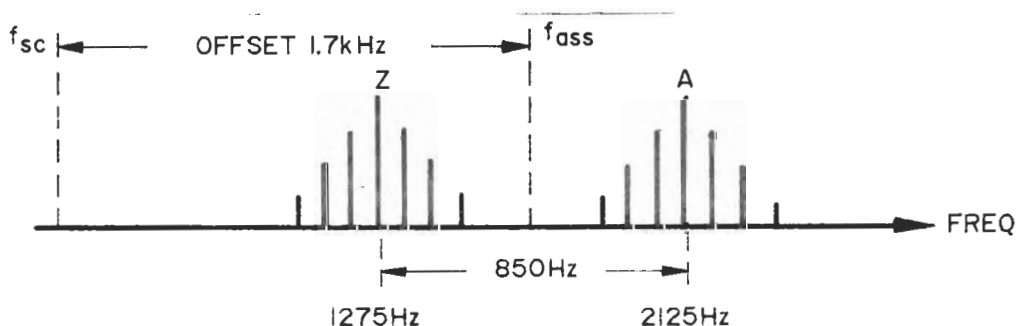

Figure 2.17

Voice

69. The military bandwidth used for analogue voice is 300 Hz to 3 kHz. This embraces sufficient frequencies at the important power levels to convey an intelligible voice signal.

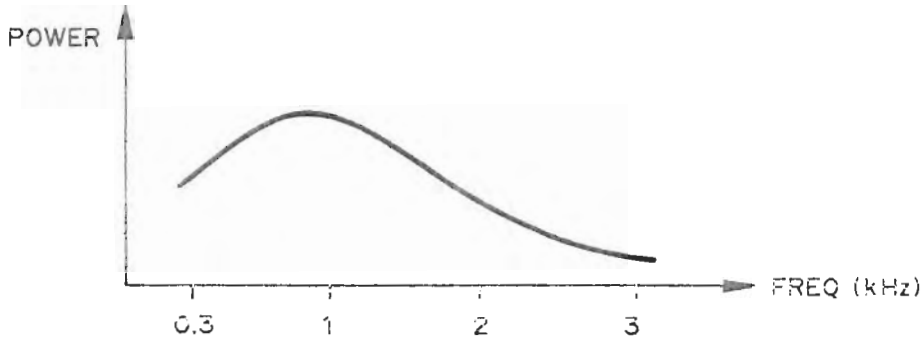

Figure 2.18 - Distribution of Power in Voice Frequencies

70. Analogue Voice appears on several DCN fixed services, usually in the lower sideband. There are at present no Fleet HF/LF services using Voice modulation, though this service may be provided in the near future. DCN voice channels employ a processing method known as LINCOMPEX.

Lincompex

71. A typical ISB DCN signal contains telegraph channels in the USB and Voice in the LSB. A normal analogue voice signal is composed of frequencies of different power levels, and of course between syllabus and word, no baseband is present at all. Consequently with a large variation in power in the LSB, the power available for the USB will fluctuate, causing variations in the telegraph power levels at the receiver. In order to produce a reasonably constant power in the LSB the voice baseband is processed in a LINKED COMPRESSION AND EXPANSION SYSTEM.

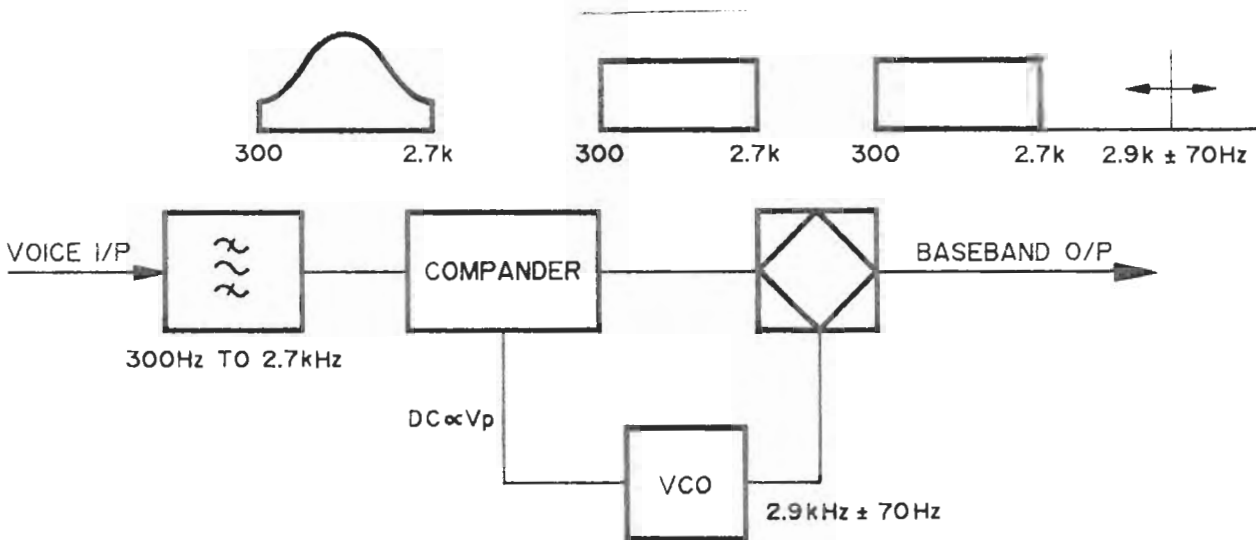

Figure 2.19 - Lincompex Transmission System

72. Transmission is as follows:

- (1) Voice input is filtered to band-pass 300 Hz to 2.7 kHz.
- (2) The COMPANDER has two outputs. The input voice frequency, but at constant amplitude, fed to the balanced mixer. A dc voltage proportional to Voice power (V_p), fed to a Voltage Controlled Oscillator.
- (3) VCO output, $2.9 \text{ kHz} \pm 70 \text{ Hz}$, proportional to the size of V_p , fed to the second input of the balanced mixer.
- (4) Combined output consists of a band of voice frequencies 300 Hz to 2.7 kHz at constant amplitude plus a $2.9 \text{ kHz} \pm 70 \text{ Hz}$ control tone. This gives a constant power level in the LSB, the control tone being present even when voice frequencies are not.

73. On Reception:

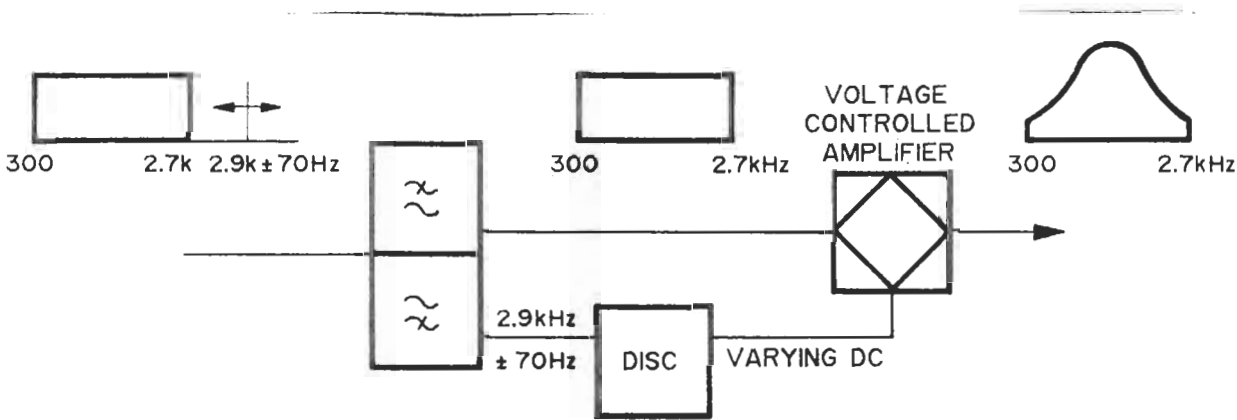

Figure 2.20 - Lincompex Reception System

- (1) The incoming signal is filtered into its two components.
- (2) The voice baseband is fed to an amplifier whose gain is controlled by a dc voltage derived from a discriminator whose input is the control tone.
- (3) Amplifier gain is thus controlled by the control tone, and will reinsert the voice power fluctuations.

Facsimile

74. Strictly a Single Service function, the transmission of the Fleet Weather Broadcast (B14A) for reception and display on Facsimile Chart Recording Outfits (RED) is from HMS INSKIP, the signal originating at the Fleet Weather Centre at NORTHWOOD. Fig 2.21 shows the form of the signal.

ie: A 2.55 kHz tone ± 400 Hz (HF) ± 150 Hz (LF) Black to White.

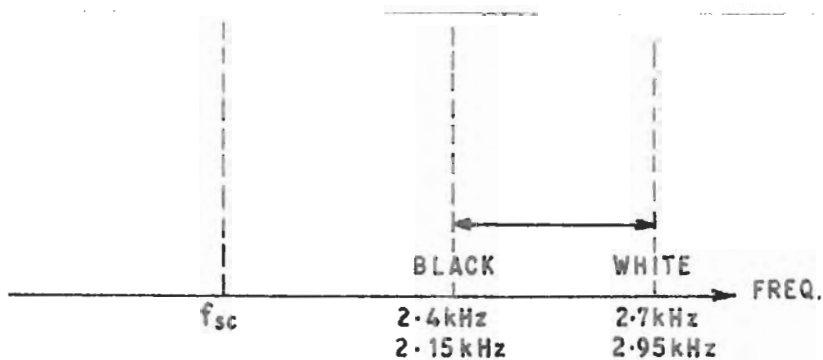

Figure 2.21 - Facsimile Keying Signal

MULTIPLEXING

75. Two methods of multiplexing Keystreams are in general use in DCN and Naval Telecommunications, Frequency Division and Time Division. A third method, common to Satcoms - Code Division, will be considered in that module.

Frequency Division Multiplex (FDM)

76. A single FST channel does not utilise the allocated bandwidth efficiently. In FDM a number of FST telegraph channels are accommodated in one sideband. A DCN HF fixed service (6 kHz B/W) normally carries eight telegraph channels in one sideband. In order to preserve a fairly wide shift between the two tones of each channel (340 Hz - see Annex A) the channels are interleaved.

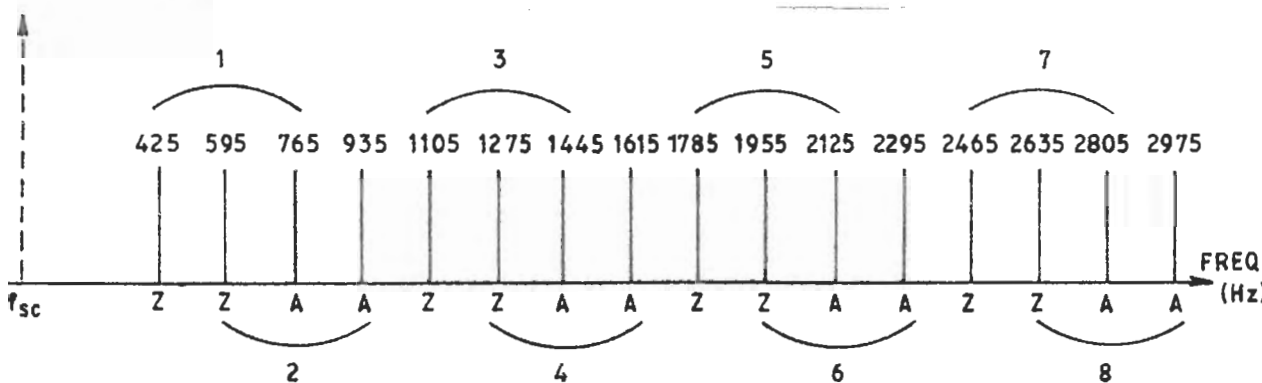

Figure 2.22

Eight further channels of telegraphy, or an analogue voice channel are found in the other sideband.

77. In Naval use the Fleet Broadcasts are usually multichannel FDM transmitted, but received as single channel signals.

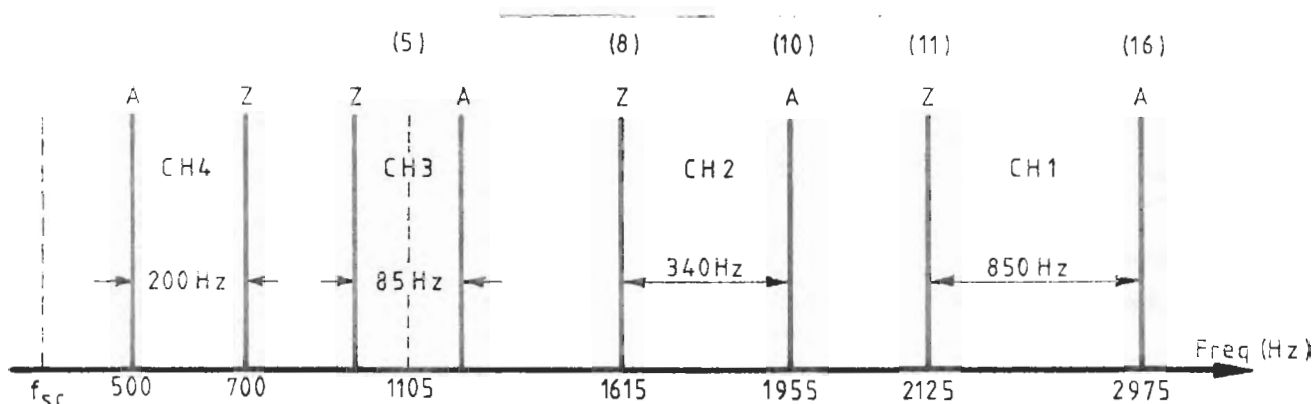

Figure 2.23

So in order to receive Channel 1, apply 2.55 kHz offset and select positions 11 and 16 on the TTVF(B) or offset 1.7 kHz and use positions 6 and 11. The detailed instruction will be given in RNCP 1.

78. BT uses FDM extensively to gain line economies in both speech and data transmission as follows:

- (1) DC Lines - each dc line signal at up to 100 BAUDS is represented by a pair of audio tones, 12 such pairs of tones being multiplexed to form a composite signal at the speech bandwidth of 300 Hz - 3.4 kHz.
- (2) Speech Lines - 12 speech channels, each of 4 kHz bandwidth, are multiplexed as lower sidebands of carrier system frequencies of 64-108 kHz to form a basic 12-channel group at a frequency of 60-108 kHz.

Improvements in cable design have made it possible to introduce a system carrying 60 telephone channels. 5 × 12-channel groups, each in the frequency band 60-108 kHz, modulate carrier frequencies of 420 kHz, 468 kHz, 516 kHz, 564 kHz and 612 kHz. Combination of the lower sidebands in each case gives a "supergroup" having a frequency range of 312-552 kHz.

By use of coaxial cables, it is possible to introduce a further level of modulation to form a "hypergroup" consisting of 15 supergroups. The "hypergroup" has a frequency range of 312-4028 kHz.

Time Division Multiplexing (TDM)

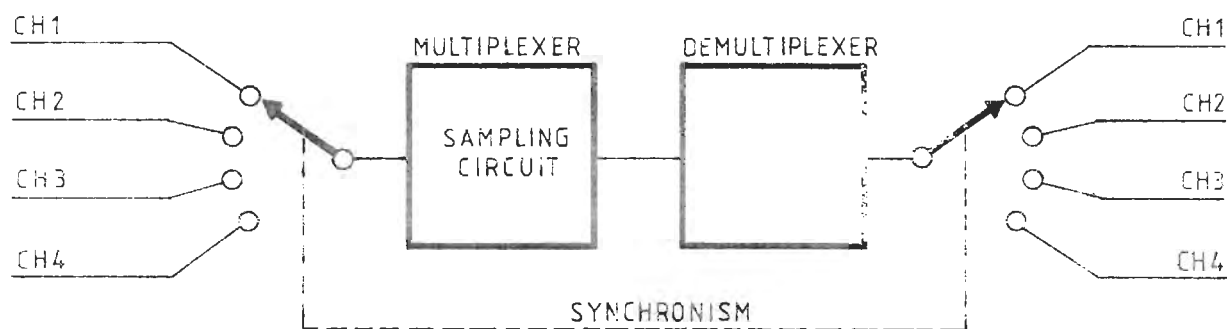

Figure 2.24

79. The input channels are sampled at a certain frequency related to their BAUD SPEED. The sampled channels then pass over the link (which requires a wider bandwidth to accommodate the high switching speed harmonics) and are reconstructed at the Distant Terminal.

80. This system is very common on DCN fixed services where several channels of the FDM system may each be further TDM into two. This system includes Error Detection and Correction using the ARQ System.

Statistical Time Division Multiplexing

81. An extension of the concept of TDM in that instead of allocating high speed aggregate channel capacity in a fixed manner with each low speed channel being allocated its share of time whether it needs it or not, a statistical multiplexer will monitor each of the low speed channels at the rated speed of that channel, but will only allocate high speed channel capacity when there is data to be transmitted.

82. Where the low speed channels are lightly utilised, it is possible for the link to handle data from low speed channels whose aggregate data rate is far in excess of the high speed channel speed. It is of note that the maximum throughput of a statistical multiplexer is the same as for basic TDM. However, the basic device will only achieve that throughput when each of the low speed channels is operating at maximum capacity whereas the statistical multiplexer serves more, but less heavily utilised channels to achieve a higher average throughput across the multiplexed link.

83. Because the combined data rates of the low speed channels exceed that of the high speed channel, large buffers are necessary in statistical multiplexers. Flow control is necessary in the event of buffers becoming overloaded.