

MARK VI

Date of design:- 1924.

This is very similar to the Mark V type except that the microphone is replaced by a moving coil unit.

The moving coil consists of a small metal former (1) wound with enamelled copper wire (3), and is screened into the diaphragm (2) of the hydrophone.

When the diaphragm (2) vibrates the coil is caused to oscillate between the poles of an electromagnet (10). Thus an alternating current is induced to the coil, the frequency of which is the same as the frequency of the diaphragm vibrations. This induced current is applied to the input terminals of the amplifier.

The resistance of the field coil (12) is normally about 40 ohms and the exciting current through this coil should not exceed 0.5 amperes.

The resistance of the moving coil is of the order of hundreds of ohms. It is therefore possible by means of a single Menotti Test or actually by measuring the resistance to determine which are the fixed and which the moving coil leads; thus obviating the danger of putting any voltage across the moving coil.

A diagrammatic sketch of the moving coil unit is shown in figure a.

Owing to its complicated nature and costly maintenance the moving coil hydrophone installation is being replaced by the microphone.

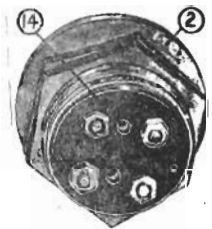

Fig. g.

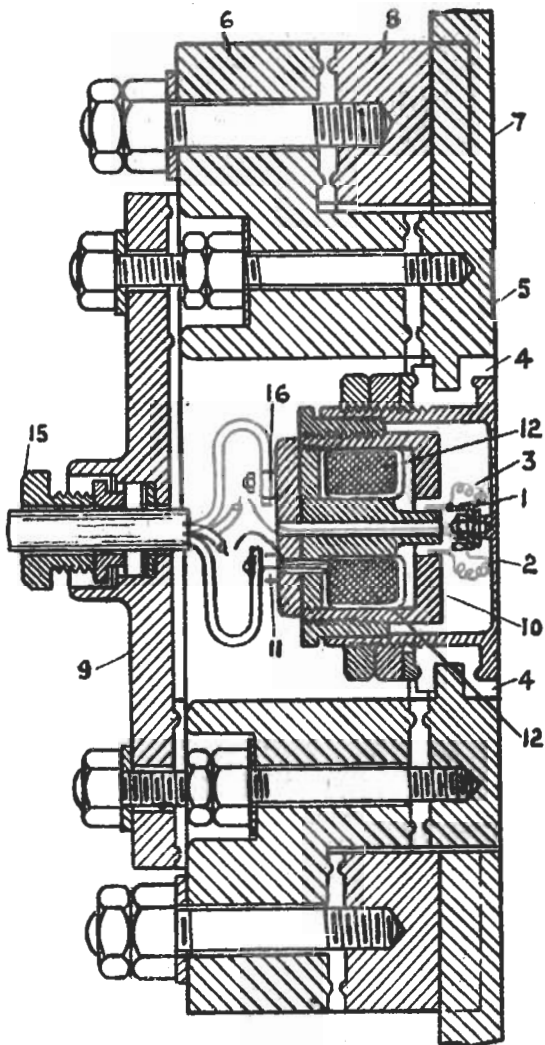

Fig. a.

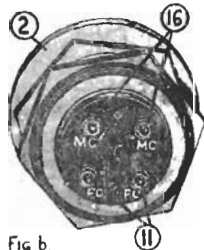

Fig. b.

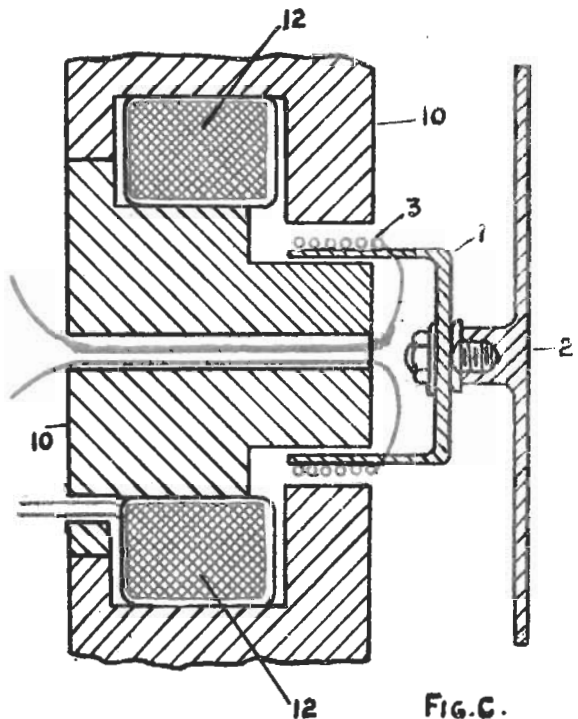

Fig. c.