

LOCAL HF COMMUNICATIONS - PORTLAND AND CLYDE

INTRODUCTION

1 The Clyde and Portland groups of transmitter and receiver stations were developed separately to fulfil unique roles in support of submarine operations and sea training respectively. These roles will continue to be relevant for the foreseeable future.

2 Traditionally the implementation was in accordance with the practices of the 1970s with the siting of remote stations and commcens being fixed by geographical restraints. The systems were very labour intensive and involved a lot of real estate.

3 During the update of equipment programme, opportunity was taken to modernise, reducing both manpower and real estate requirements.

SYSTEM

4 The two systems are very similar, the equipment being identical to that provided for the UKMACCS. The systems are completely separate having no communications with any other system except as required by SSE(UK) to fulfil his engineering commitments.

5 Each system consists of a dual processor arrangement at a System Control Centre controlling the operation of equipment at remote unmanned transmitter and receiver stations. There is a control console, from which commands are originated for altering the status of any controlled equipment and monitoring its performance. Separately provided audio channels feed the transmitted and received information between operating positions and the remote sites with some connections to and from stations outside the main remote control system. Initially the audio signals will be plain voice, RATT or morse, but secure voice channels may be provided in the future.

6 To attain maximum flexibility in allocation of transmitter drive or receiver equipment, all modulation is generated/decoded at the Commcen and fed to/from the remote sites as audio signals, patching to the required line and associated equipment being carried out at the Commcen.

7 Interconnecting lines are generally BT landlines, with certain Clyde links being provided on the Clyde Radio Link system.

8 The transmit sub-system comprises:

- (1) Transmitter Drive Outfit (TDE) - 12 off remotely controlled synthesised hf drive units frequency range 1.5 to 30 MHz.

(2) Drive Combiner Outfit (TDF). Accepts inputs from drives in groups of four and combines them into three X and three Y rf outputs. Frequency range 1.6 to 28 MHz.

(3) Power Bank Outfit (WBP). Accepts X and Y outputs from drive combiners producing one X and one Y output. Employs six 1 kW wideband amplifiers operating in parallel with two additional as spares. Frequency range 1.6 to 28 MHz.

(4) Aerial Exchange. Remotely controlled five input, five output switching matrix. Switches X and Y outputs of Power Bank between aerials and dummy loads with power meters.

(5) Aerials. A selection of Conifan and monopole aerials giving full frequency range coverage.

9 The receiver sub-system comprises:

(1) Aerials. A selection of Conifan and monopole aerials giving full frequency range coverage.

(2) Aerial Multicoupler Outfit (EAV). 10-way multicoupler giving 19 outputs from each aerial. Frequency range 1.65-30 MHz.

(3) Aerial Exchange Outfit (ESG). 16 switched outputs from 38 inputs. Frequency range 30 kHz to 30 MHz.

(4) Receivers (CHM). 16 off remotely controlled, synthesised, double superhet receivers frequency range 10 kHz to 30 MHz.

10 Location of sites are:

(1) PORTLAND

COMMCEN - Portland COMMCEN
Transmit Site - Portland Bill
Receive Site - The Verne

(2) CLYDE

COMMCEN - Faslane COMMCEN
Transmit Site - Toward Taynuilt, Machrihanish
Receive Site - Clachmackenny, Machrihanish & Tiree

SYSTEM CONTROL

- 11 Control of the following system functions is possible:
- (1) Channel frequency pair selection (1 × Tx, 1 × Rx).
 - (2) Channel allocations.
 - (3) Fault diagnosis.

RECEIVER CONTROL

- 12 Control of the following is possible:
- (1) Selection of Rx aerial.
 - (2) Receiver control including:
 - a. Tuning.
 - b. Receive mode.
 - c. AGC time constant.
 - d. Filter bandwidth.
 - e. Reconstituted carrier.
 - (3) Stations Services.

TRANSMITTER CONTROL

- 13 Control of the following is possible:
- (1) Drive control including:
 - a. Tuning
 - b. Selection of X or Y output.
 - c. Power Boost.
 - (2) Power Bank control including:
 - a. Selection of 1 kW amps for operation.
 - b. HT power switching.

c. Selection of Bank Activation Mode: OFF, MANUAL or AUTOMATIC.

d. Control and monitoring of Cooling and Fire Protection.

e. Power output monitoring.

(3) Aerial and Dummy Load selection.

(4) Station Services.

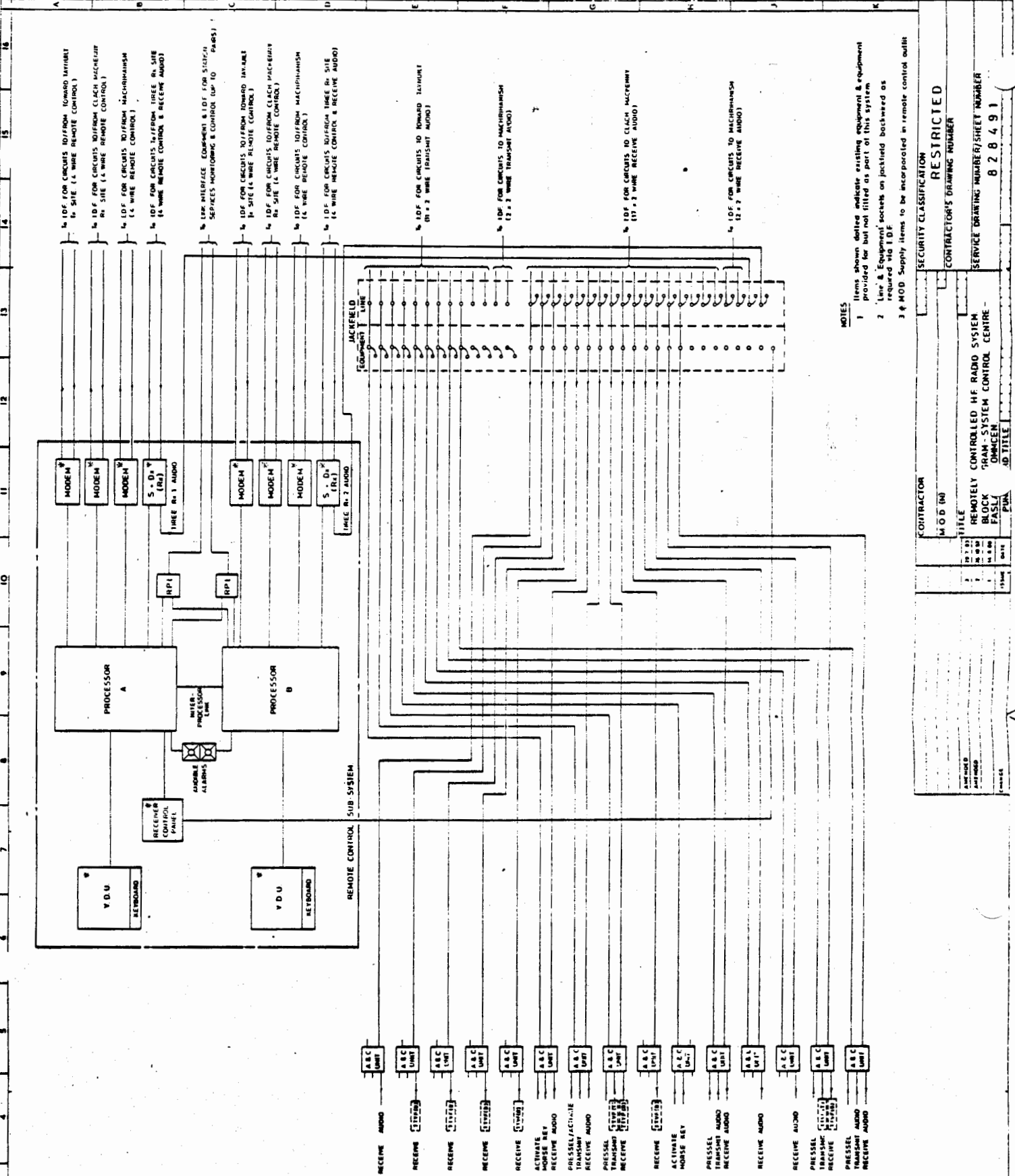

- NOTES**
- 1 Items shown dashed indicate existing equipment & equipment provided for but not fitted as part of this system.
 - 2 'Ler' & Equipment sockets on jackfield backwired as required via IDF.
 - 3 # MOD Supply items to be incorporated in remote control outfit.

SECURITY CLASSIFICATION RESTRICTED	
CONTRACTOR'S DRAWING NUMBER 8 2 8 4 9 1	
SERVICE DRAWING NUMBER/SHEET NUMBER 8 2 8 4 9 1	
CONTRACTOR MOD (M)	TITLE REMOTELY CONTROLLED HF RADIO SYSTEM BLOCK FROM SYSTEM CONTROL CENTRE - OMNISCEN
AUTHOR 15/04/88	DRAWN 15/04/88
CHECKED 15/04/88	DESIGNED 15/04/88
APPROVED 15/04/88	PWA

RESTRICTED
 DRAWING NUMBER/SHEET NUMBER
 8 2 8 4 9 1

SECURITY CLASSIFICATION

RESTRICTED

SERVICE DRAWING NUMBER / SHEET NUMBER

8 2 8 4 8 6

USED ON

JACKFIELD

PRESSEL

AUDIO

DRIVE OUTFIT 10E1

DRIVE 1

DRIVE 2

DRIVE 3

DRIVE 4

DRIVE 5

DRIVE 6

DRIVE 7

DRIVE 8

DRIVE 9

DRIVE 10

DRIVE 11

DRIVE 12

AEC UNIT

AEC UNIT

AEC UNIT

AEC UNIT

AEC UNIT

AEC UNIT

AEC UNIT

AEC UNIT

AEC UNIT

AEC UNIT

AEC UNIT

AEC UNIT

AEC UNIT

AEC UNIT

AEC UNIT

AEC UNIT

AEC UNIT

AEC UNIT

AEC UNIT

AEC UNIT

AEC UNIT

AEC UNIT

AEC UNIT

AEC UNIT

AEC UNIT

AEC UNIT

AEC UNIT

AEC UNIT

AEC UNIT

AEC UNIT

AEC UNIT

AEC UNIT

AEC UNIT

AEC UNIT

AEC UNIT

AEC UNIT

AEC UNIT

AEC UNIT

AEC UNIT

AEC UNIT

AEC UNIT

AEC UNIT

AEC UNIT

AEC UNIT

AEC UNIT

AEC UNIT

AEC UNIT

AEC UNIT

AEC UNIT

AEC UNIT

AEC UNIT

AEC UNIT

AEC UNIT

AEC UNIT

to MDF for CIRCUITS from FASLANE COMB-CEN

NOTES

- 1 ITEMS SHOWN DOTTED INDICATE EQUIPMENT PROVIDED FOR BUT NOT FITTED AS PART OF THIS SYSTEM.
- 2 LINE & EQUIPMENT SOCKETS ON JACKFIELDS BACKWIRED AS REQUIRED VIA I.D.F.
- 3 * M.O.D SUPPLY ITEMS TO BE INCORPORATED IN REMOTE CONTROL OUTFIT.

ERTS

CHECKED

DRAWN

RS

CONTRACTOR

AMENDED	5	27.7.80	M O D I R I	TITLE
AMENDED	4	18.10.80		
AMENDED	3	10.7.80		
AMENDED	2	18.7.80		
AMENDED	1	18.6.80		

SECURITY CLASSIFICATION

RESTRICTED

CONTRACTOR'S DRAWING NUMBER

REMOVED CONTROL HF RADIO SYSTEM
BLOCK DIAGRAM - TOWARD TAYNUIT 1x STATION
PUNCH CARD TITLE

SERVICE DRAWING NUMBER / SHEET NUMBER

8 2 8 4 8 6

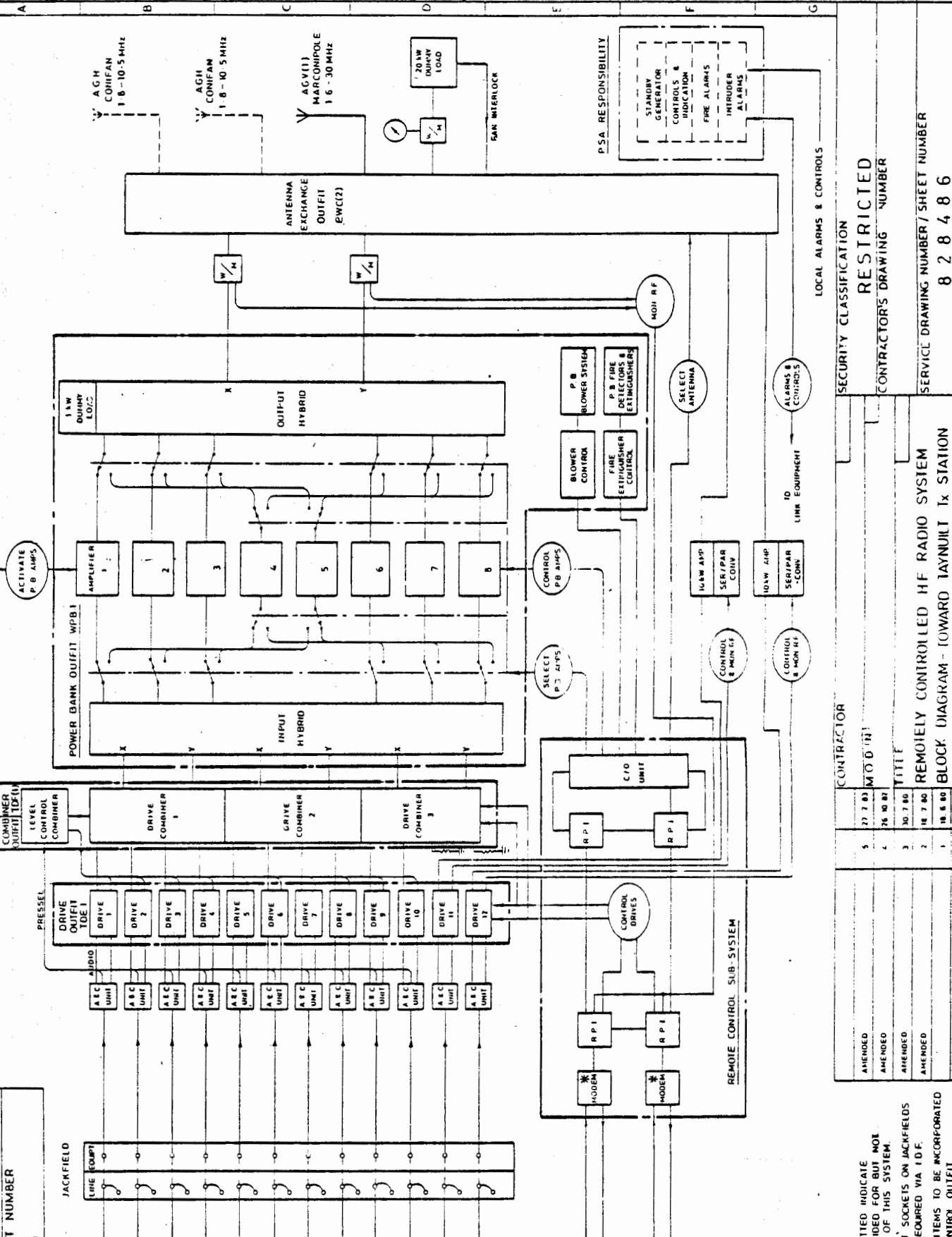

SECURITY CLASSIFICATION

RESTRICTED

SERVICE DRAWING NUMBER / SHEET NUMBER

8 2 8 4 8 7

USED ON

1 2 3 4 5 6 7 8 9 10 11

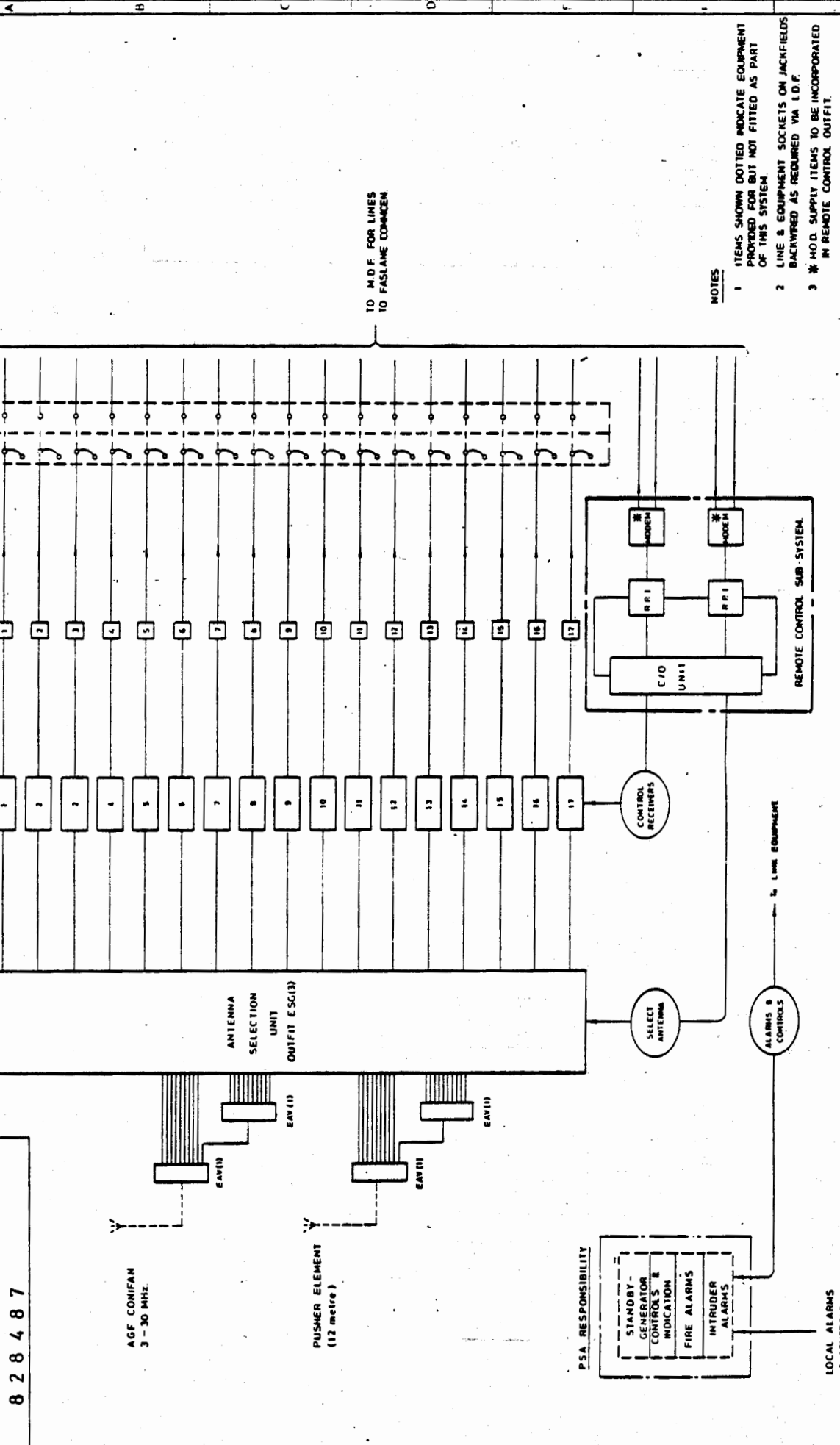

NOTES

- 1 ITEMS SHOWN DOTTED INDICATE EQUIPMENT PROVIDED FOR BUT NOT FITTED AS PART OF THIS SYSTEM.
- 2 LINE & EQUIPMENT SOCKETS ON JACKFIELDS BACKWired AS REQUIRED VIA I.O.F.
- 3 * MOD. SUPPLY ITEMS TO BE INCORPORATED IN REMOTE CONTROL OUTFIT.

SECURITY CLASSIFICATION

RESTRICTED

CONTRACTOR'S DRAWING NUMBER

REMOVED
 REMOVED
 REMOVED
 REMOVED

REMOVED CONTROLLED HF RADIO SYSTEM

BLOCK DIAGRAM - CLACH MACKENNY R. STATION

ISSUE DATE

ISSUE	DATE	CHANGES
1	12 8 50	
2	17 2 50	
3	24 2 50	
4	26 10 51	
5	27 7 53	

CHECKED

DRAWN

REVISION

1

SECURITY CLASSIFICATION

RESTRICTED

SERVICE DRAWING NUMBER / SHEET NUMBER

8 2 8 4 9 5

USED ON

TRANSMITTER SITE

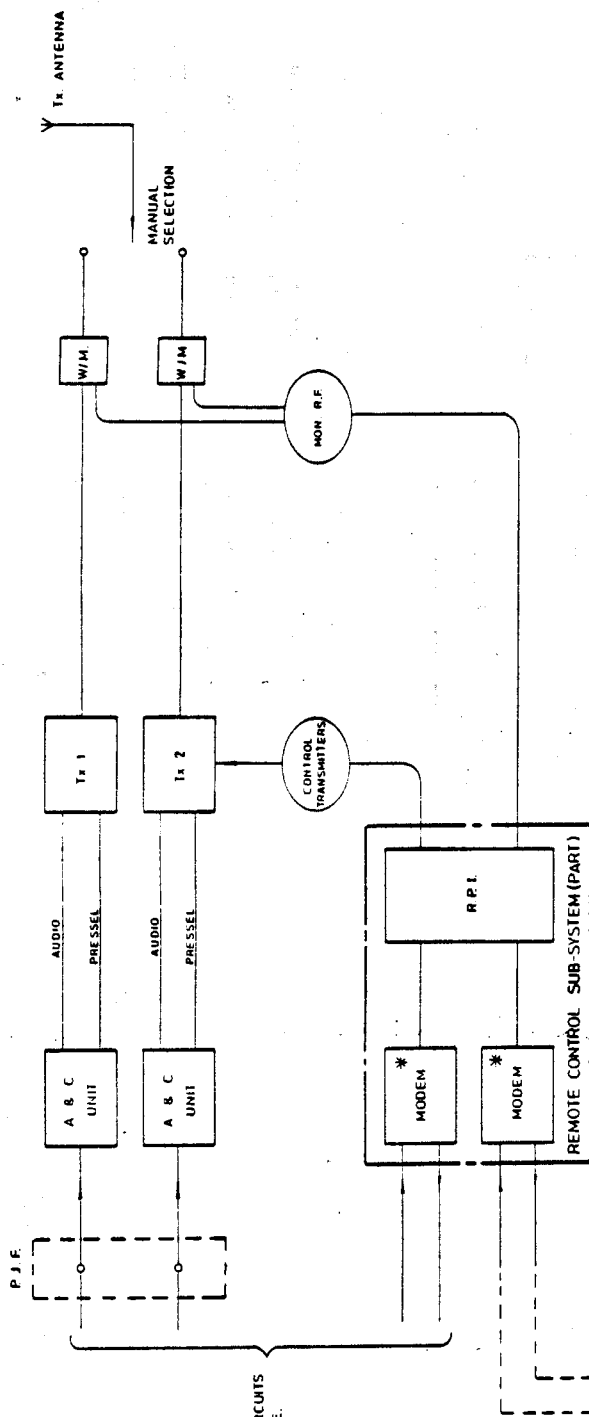

To M.D.F. FOR CIRCUITS TO/FROM FASLANE.

4 WIRE INTER SITE LINK

RECEIVER SITE

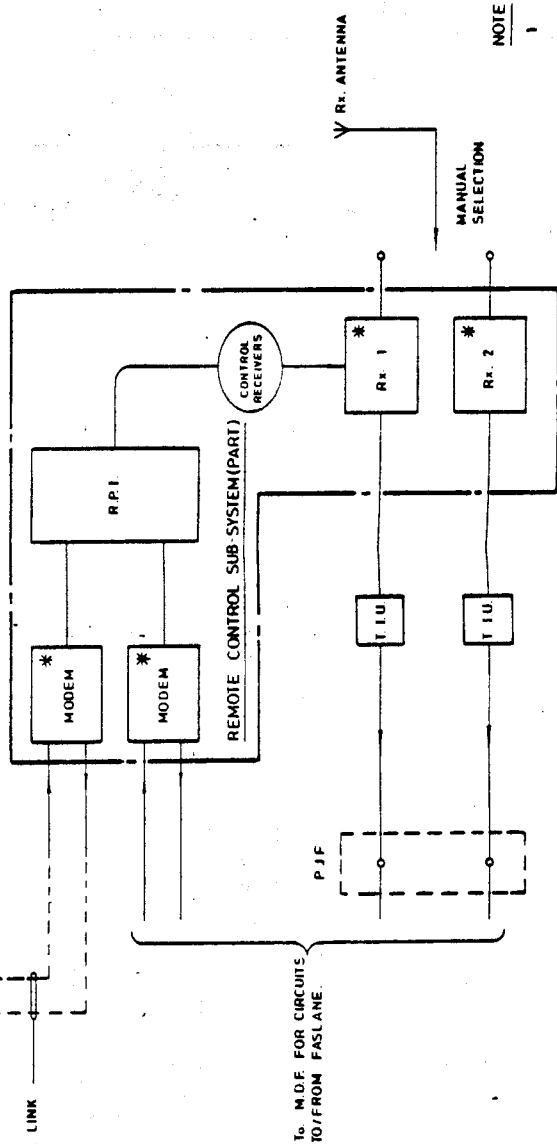

To M.D.F. FOR CIRCUITS TO/FROM FASLANE.

NOTE

- 1 Items shown dotted indicate equipment provided for but not fitted as part of this system.
- 2 * M.O.D. Supply items to be incorporated in remote control outfit.

SECURITY CLASSIFICATION

RESTRICTED

CONTRACTOR'S DRAWING NUMBER

REMOTELY CONTROLLED H.F. RADIO SYSTEM TRANSMITTERS & RECEIVERS - MACHRIHANISH

SERVICE DRAWING NUMBER / SHEET NUMBER

8 2 8 4 9 5

DATE	
CHECKED	
APP'D	R.S.

SECURITY CLASSIFICATION
RESTRICTED
SERVICE DRAWING No./SHT. No
8 2 8 5 3 8

USED
ON

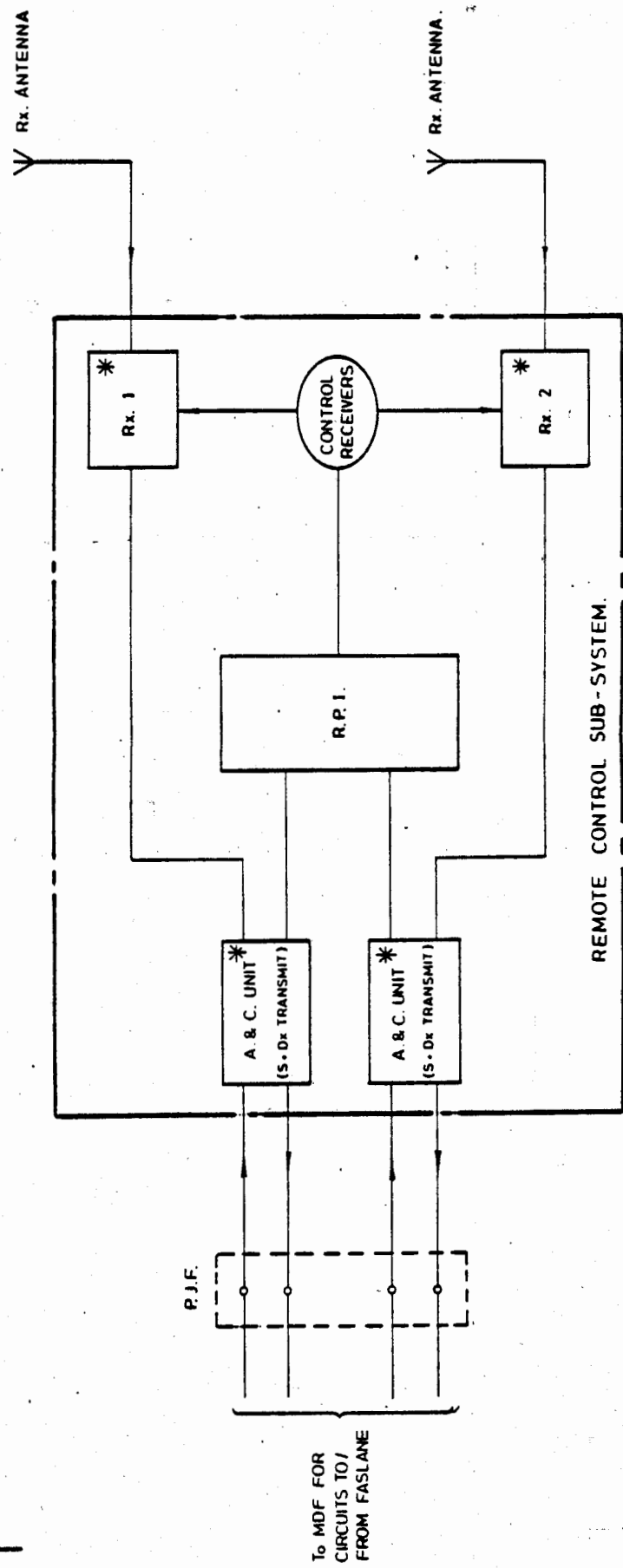

NOTE

- 1 Item shown dotted indicates equipment provided for but not fitted as part of this system.
- 2 * M.O.D. Supply items to be incorporated in remote control outfit.

CERT'D
CHECKED
DRAWN
12 B

CONTRACTOR	SECURITY CLASSIFICATION
M.O.D.(N)	RESTRICTED
TITLE	CONTRACTOR'S DRG. No.
AMENDED.	SERVICE DRAWING No./SHT. No
2 26.7.83	8 2 8 5 3 8
1 20.4.83	
ISSUE DATE	
CHANGE PUNCH	
J TITLE	

REMOTE CONTROL SUB-SYSTEM.

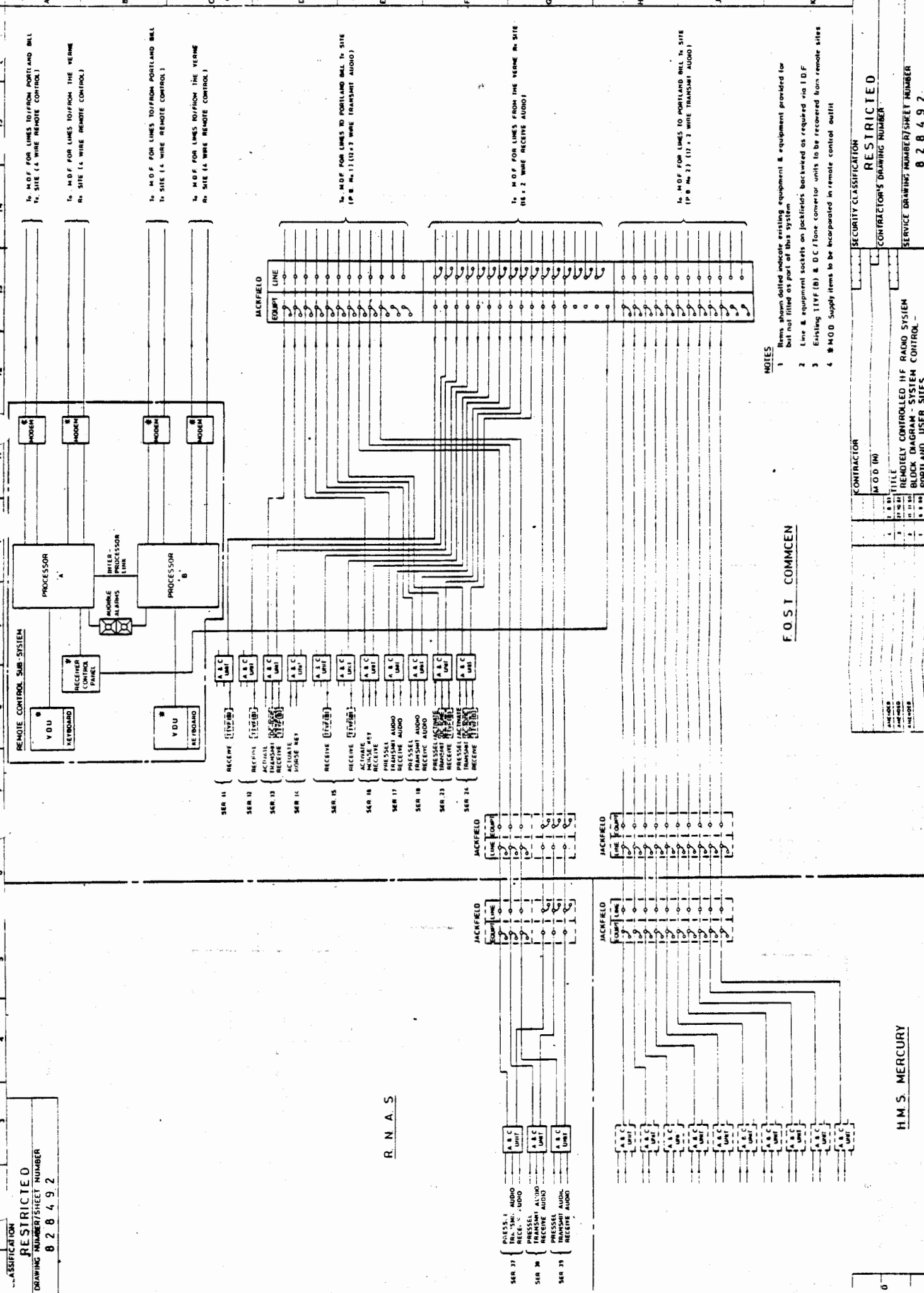

To M.D.F. FOR LINES TO/FROM PORTLAND BELL
IN SITE (4 WIRE REMOTE CONTROL)

To M.D.F. FOR LINES TO/FROM THE VERNE
IN SITE (4 WIRE REMOTE CONTROL)

To M.D.F. FOR LINES TO/FROM PORTLAND BELL
IN SITE (4 WIRE REMOTE CONTROL)

To M.D.F. FOR LINES TO/FROM THE VERNE
IN SITE (4 WIRE REMOTE CONTROL)

To M.D.F. FOR LINES TO PORTLAND BELL IN SITE
(P.B. No. 1) (11 + 1 WIRE TRANSMIT AUDIO)

To M.D.F. FOR LINES FROM THE VERNE IN SITE
(P.B. No. 2) (11 + 2 WIRE RECEIVE AUDIO)

To M.D.F. FOR LINES TO PORTLAND BELL IN SITE
(P.B. No. 3) (11 + 2 WIRE TRANSMIT AUDIO)

- NOTES**
- 1 Items shown dotted indicate existing equipment & equipment provided for but not fitted as part of this system
 - 2 Line & equipment sockets on Jackfields backwired as required via IDF
 - 3 Existing TTYF (B) & D.C. Tone converter units to be recovered from remote sites
 - 4 # MOD Supply items to be incorporated in remote control outfit

F.O.S.T. COMMENCEN

R.N.A.S.

CONTRACTOR'S DRAWING NUMBER		SECURITY CLASSIFICATION	
MOD (M)		RESTRICTED	
TITLE		CONTRACTOR'S DRAWING NUMBER	
REMOTE CONTROL HF RADIO SYSTEM		8 2 8 4 9 2	
BLOCK DIAGRAM - SYSTEM CONTROL -		SERVICE DRAWING NUMBER/SHEET NUMBER	
PORTLAND USER SITES		8 2 8 4 9 2	
PUNCH CARD TITLE		CONTRACT	
REV	DATE	BY	CHKD
1	11/04		

CLASSIFICATION
RESTRICTED
DRAWING NUMBER/SHEET NUMBER
8 2 8 4 9 2

H.M.S. MERCURY

SECURITY CLASSIFICATION
RESTRICTED
 SERVICE DRAWING NUMBER / SHEET NUMBER
8 2 8 4 8 5

USED ON

AGF CONIFAN
 3 - 30 MHz.

PUSHER ELEMENT
 (12 metre)

M.D.F. for LINES
 TO F.O.S.T. COMM-EN

NOTES

- 1 * M.D.D. SUPPLY ITEMS TO BE INCORPORATED IN REMOTE CONTROL OUTFIT.
- 2 ITEMS SHOWN DOTTED INDICATE EQUIPMENT PROVIDED FOR BUT NOT FITTED AS PART OF THIS SYSTEM
- 3 LINE & EQUIPMENT SOCKETS ON JACKFIELD BACKWIRRED AS REQUIRED VIA I.O.F.

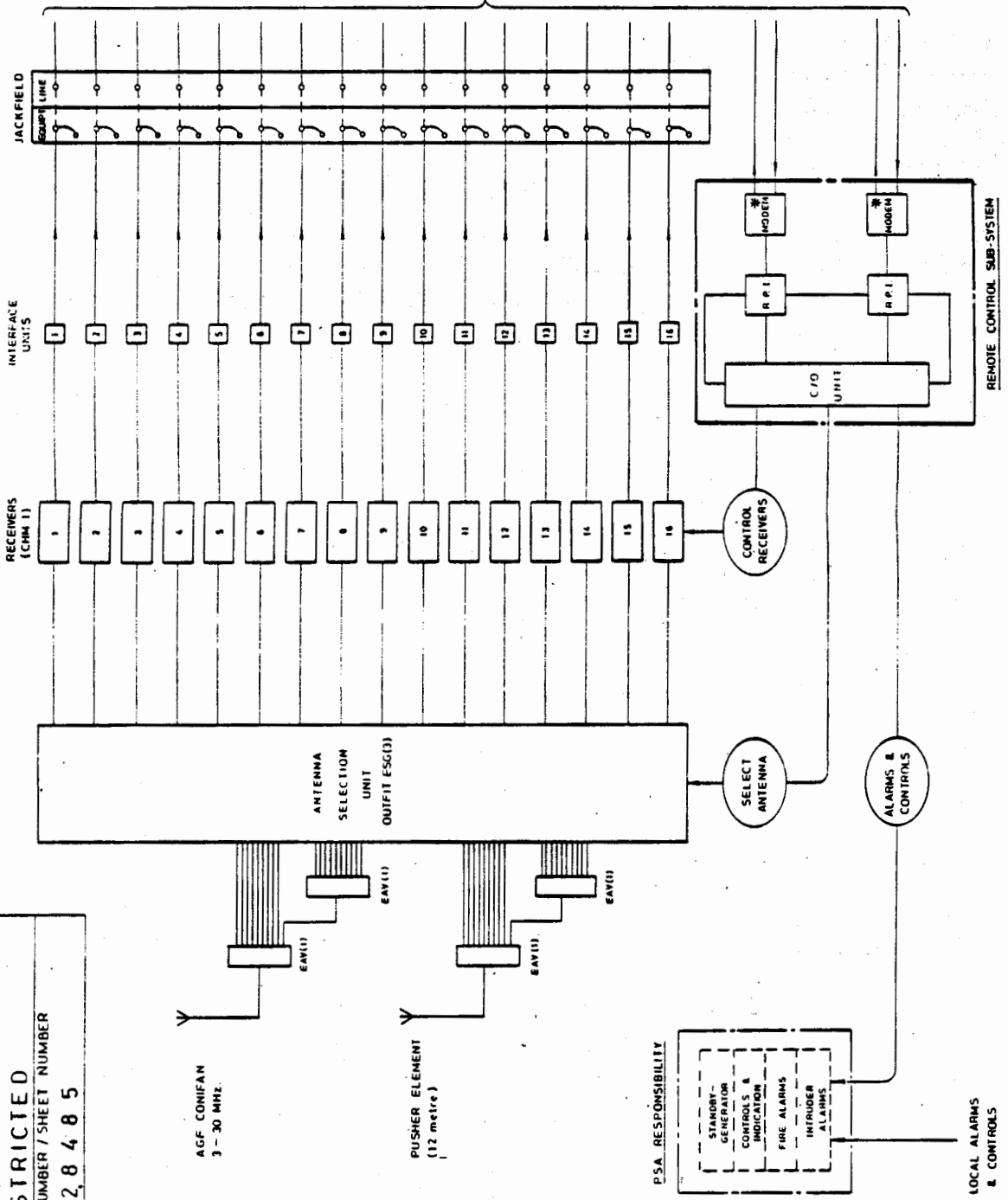

SECURITY CLASSIFICATION
RESTRICTED
 CONTRACTOR'S DRAWING NUMBER
 SERVICE DRAWING NUMBER / SHEET NUMBER
8 2 8 4 8 5

AMENDED	DATE	ISSUE	CHANGE
05	22.2.83		
04	15.10.82		
03	24.7.80		
02	17.7.80		
01	12.6.80		

CONTRACTOR
 MOD (37)
 TITLE
**REMOTELY CONTROLLED HF RADIO SYSTEM
 BLOCK DIAGRAM - THE VERNE Rx STATION.**
 PUNCH CARD TITLE

SECURITY CLASSIFICATION
RESTRICTED
 DRAWN BY
 K. St. L.