

REQUIREMENT FOR S.S.B.

In view of the increasing congestion in the HF band it is obvious that signal power and bandwidth must be used in the most efficient way possible. To make the optimum use of the HF spectrum it is necessary that:-

1. The maximum possible power is used over the smallest bandwidth.
2. The radiated power available is used effectively.
3. Mutual interference is reduced between transmitters and receivers.

To obtain these objectives single sideband techniques must be used.

Comparison of S.S.B. with A.M. D.S.B.

There is no simple method to compare the relative performance of the two systems. One method, however, is to compare the transmitter power required, by both systems, to produce a given signal to noise ratio at a receiver, under ideal propagating conditions. This is considered to be a fair comparison because it is the S/N ratio that determines the intelligibility of the received signal. Diagram 3.1 shows such a comparison between an a.m. d.s.b. system modulated with a single tone sine wave and a s.s.b. system modulated with a single tone sine wave. The d.s.b. system will actually be producing 1.5 units of r.f. power, i.e. carrier 1 unit plus 0.25 units per sideband, as compared with the 0.5 unit of power in the s.s.b. system.

Another point of comparison between the two systems is the peak aerial voltage required. Referring to diagram 3.1 it will be seen that the peak aerial voltage required in the d.s.b. system is 2V units compared with 0.7V units in the s.s.b. system; to produce eventually the same S/N ratio at the receiver.

These comparisons are made under the assumption of perfect propagating conditions. Under adverse conditions the superiority of the s.s.b. system over the d.s.b. system becomes very apparent. The a.m. d.s.b. signal is subject to deterioration by selective fading which can make the signal unintelligible.

	A.M. D.S.B. SINGLE TONE SINE WAVE MODULATION	S.S.B. SINGLE TONE SINE WAVE MODULATION
RATED POWER	<p>RATED CARRIER POWER = 1</p> <p>.25 .25</p> <p>L.S.B. C U.S.B.</p>	<p>RATED P.E.P. = .5</p> <p>C U.S.B.</p>
VOLTAGE VECTORS 100% MOD N	<p>.5 .5</p> <p>L.S.B. U.S.B.</p> <p>1</p> <p>C</p> <p>PEAK ENVELOPE VOLTAGE = 2</p>	<p>.7</p> <p>U.S.B.</p>
R.F. ENVELOPE	<p>P.E.V. = 2</p> <p>P.E.P. = 4</p>	<p>P.E.V. = .7</p> <p>P.E.P. = .5</p>
RECEIVER A.F. SIGNAL VOLTAGE	<p>U.S.B. + L.S.B. = 1</p>	<p>.7</p>
NOISE VOLTAGE	<p>NOISE POWER IS PROPORTIONAL TO BANDWIDTH. THEREFORE, IF A BROADBAND NOISE LEVEL IS CHOSEN AS .1 UNIT OF VOLTAGE PER 6kc/s. BANDWIDTH, THEN THE SAME NOISE LEVEL IS EQUAL .07V PER 3kc/s. i.e. $\frac{.1^2}{6} = \frac{.07^2}{3}$ (E)</p>	
S/N	$20 \text{ LOG } \frac{1}{0.1} = 20 \text{ dB}$	$20 \text{ LOG } \frac{0.7}{.07} = 20 \text{ dB}$
	<p>i.e. THE SAME S/N RATIO</p> <p>Diag. 3.1 (F)</p>	

The diagrams 3.2 show the effects of sideband fading, carrier fading and carrier phase shift in a d.s.b. a.m. signal. All these result in either loss of signal amplitude at the receiver, distortion at the receiver or both. Selective fading within the one sideband of the s.s.b. system only changes the amplitude and the frequency response of the signal. It very rarely produces enough distortion to cause the received signal or voice to be unintelligible.

From these comparisons it is obvious that the s.s.b. system has many advantages over the d.s.b. system. It is possible to produce the same S/N ratio at a receiver with less power or to have an increased signal at the receiver with the same power. Also there is a considerable amount of saving in spectrum space by transmitting only one sideband or alternatively twice the amount of information can be transmitted in the same bandwidth, i.e. 6 kc/s, as required by the d.s.b. system.

TRANSMITTED SIGNAL

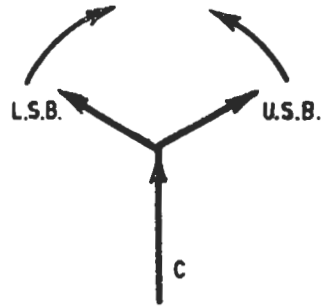
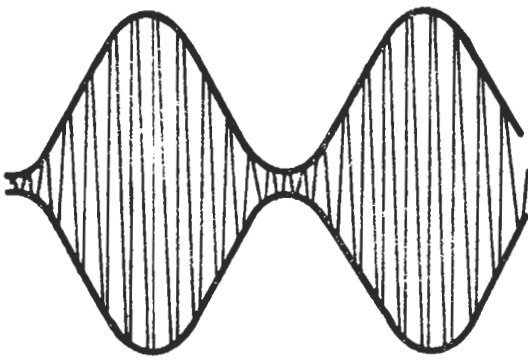

SIDEBAND FADING

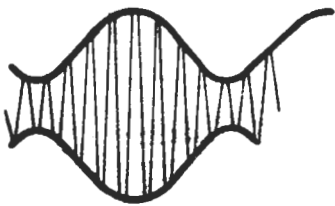

Rx'd SIGNAL
(ONE SIDEBAND LOST)

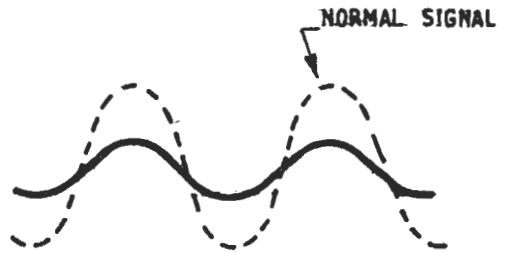

DEMODULATED SIGNAL
SOME DISTORTION
LOSS OF AMPLITUDE
DETERIORATION OF S/N RATIO

CARRIER FADING

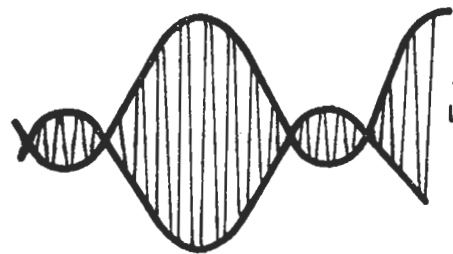

RECEIVED SIGNAL CARRIER
REDUCED BY $\frac{1}{2}$.

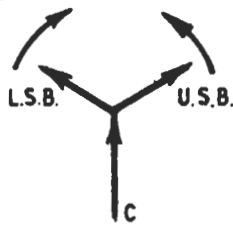

DEMODULATED SIGNAL
SEVERE DISTORTION.

CARRIER PHASE SHIFT

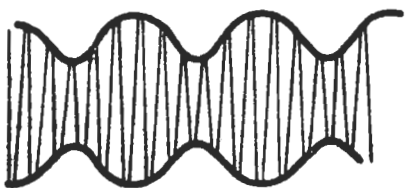

RECEIVED SIGNAL
CARRIER SHIFTED BY 90°
SIGNAL IS PHASE MODULATED



DEMODULATED SIGNAL
COMPLETE LOSS OF INTELLIGIBILITY

The use of s.s.b. transmissions is not simple. The main requirement for an efficient system is the need for frequency correspondence between the transmitted frequency and the receiver frequency. As will be seen later, before demodulation can be carried out in the receiver, a carrier, of correct frequency must be added to the signal at the receiver. It was this requirement for frequency correspondence that has delayed the widespread use of s.s.b. techniques until the present day.

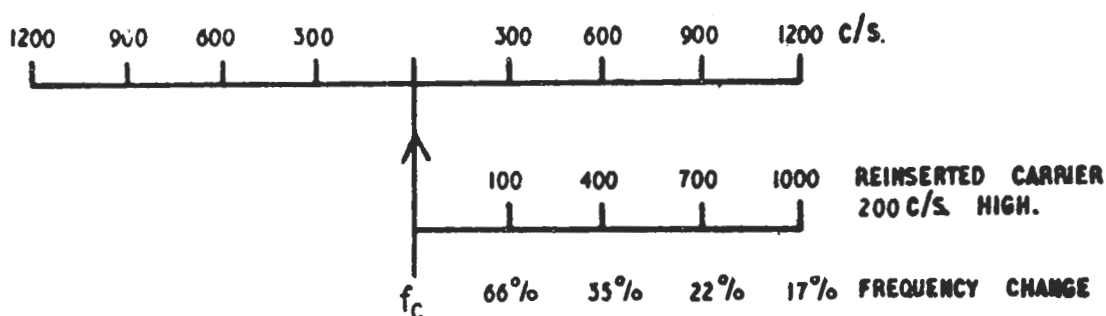

Diag. 3.3

The diagram 3.3 shows the effect of reinserting the carrier frequency at the receiver 200 cycles high. This 200 cycle error would not be important in d.s.b., but in s.s.b. the pitch distortion would be unacceptable. The maximum error acceptable is of the order 10 to 20 cycles which means a stability in transmitter and receiver frequency of the order of 1 part in 10^7 at 30 Mc/s. Until recently this has been achieved by transmitting a pilot carrier with the single sideband. This pilot or reduced carrier is amplified by the Receiver and reinserted for demodulation. The pilot carrier was also used by the receiver for a.f.c. and a.g.c. These systems were rather costly and difficult to maintain efficiently. It is only in recent years that the stability of crystal oscillators and the concept of frequency synthesis has given the stability required for a true s.s.b. system to work unattended. From the security aspect as well, the pilot carrier system is not acceptable for service operation.

Introduction to S.S.B. Techniques

A sine wave conveys very little information since it repeats over and over again. When a wave is modulated either in amplitude or frequency, it is no longer simply a sine wave, but instead a mixture of several wave of slightly different frequencies superimposed on each other.

The equation for an amplitude modulated wave is often written

$$e = E_o (1 + m \sin f_m t) \sin 2\pi f_c t$$

where e = the instantaneous value of the modulated wave

E_o = the maximum value of the carrier

f_m = the frequency of the modulating wave

m = the depth of modulation

f_c = the r.f. carrier frequency

This expression can be multiplied out

$$e = E_o \sin 2\pi f_c t + mE_o \sin 2\pi f_m t \sin 2\pi f_c t$$

expanding the last term in functions of the sum and difference angles.

$$e = E_o \sin 2\pi f_c t + \frac{mE_o}{2} \cos 2\pi(f_c - f_m)t - \frac{mE_o}{2} \cos 2\pi(f_c + f_m)t$$

Carrier frequency + Lower sideband + Upper sideband.

The result shows the existence of two sideband frequencies, one above and one below the carrier f_c . If the modulating frequency is no longer the simple sine wave f.m. but a whole series of modulating frequencies, such as a speech wave form, then the sideband frequency will have to include all these frequencies, say to to 3 kc/s for speech and 6 kc/s for music.

It must be noted that the amplitude of the sidebands (when the depth of modulation is 100%) is half the amplitude of the carrier voltage wave.

The total energy in a modulated wave is obtained by adding the energy contents of the carrier and the two sidebands.

Power in the carrier is proportional to E_o^2

Power in the lower s.b. is proportional to $(\frac{mE_o}{2})^2 = \frac{m^2 E_o^2}{4}$

Power in the upper s.b. is proportional to $(\frac{mE_o}{2})^2 = \frac{m^2 E_o^2}{4}$

So that the increase in power when the carrier is modulated to a depth of 100% is proportional to:-

$$\frac{E_o^2}{4} + \frac{E_o^2}{4} = \frac{E_o^2}{2}$$

i.e. Total Power = Carrier power $(1 + \frac{1}{2})$

i.e. the sidebands carry only one third of the total power radiated when the depth of modulation is 100% and this power must be provided by the modulator unit itself.

Since all the information being transmitted appears in each sideband, it is obvious that to increase efficiency only one sideband need be transmitted and even the carrier frequency is a waste of power and can be discarded. Under these conditions all the available power can be utilised to transmit the one sideband containing all the information.

The nature of a s.s.b. signal

An s.s.b. signal is an audio signal converted to a radio frequency, with or without inversion. For instance, a single 1 kc/s tone is used to amplitude modulate a 100 kc/s r.f. The resulting analysis gives the three waves, the carrier of 100 kc/s, the upper sideband of 101 kc/s which is a s.s.b. signal without inversion. The lower sideband is also an s.s.b. signal but this time with inversion. Inversion is not very obvious in the simple case quoted but if the modulation is a voice signal containing audio frequencies from say 300 c/s to 3000 c/s, then when frequency translation or modulation takes place inversion becomes an important factor.

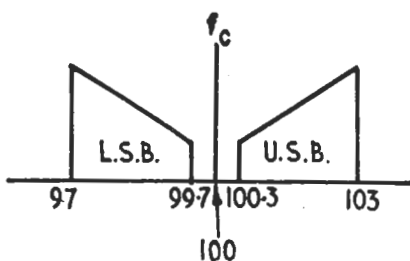
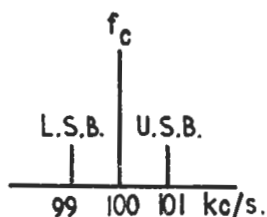

The S.S.B. Generator

The majority of s.s.b. generators utilise a Balanced Modulator circuit, followed by a filter. Theoretically the 100 kc/s r.f. input is completely cancelled out in the balanced modulator and the modulator

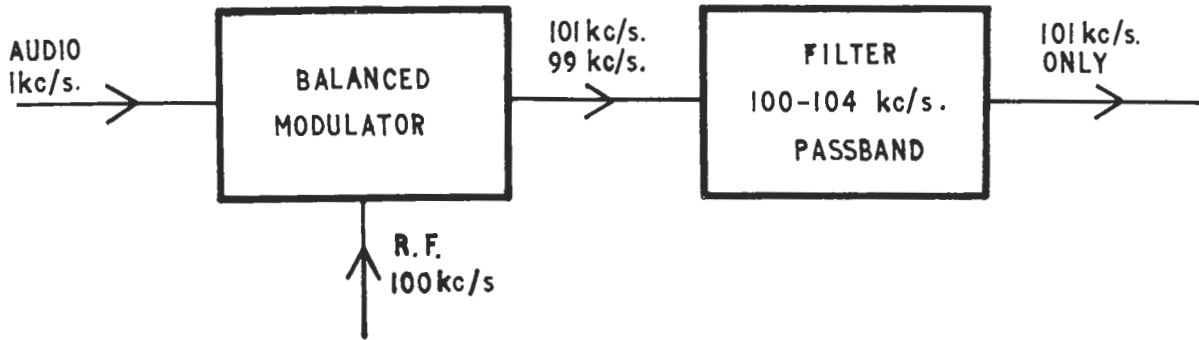

Diag. 3.5

output is basically two frequencies

1. the r.f. + the audio, the upper sideband, and
2. the r.f. - the audio, the lower sideband.

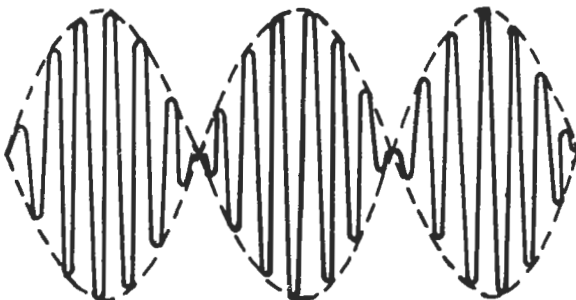

BALANCED MODULATOR OUTPUT
SINGLE TONE

i.e. 101 kc/s. + 99 kc/s.



SINGLE TONE OUTPUT AFTER
FILTERING OUT THE L.S.B.
THIS IS THE S.S.B. SIGNAL
THAT IS TO BE TRANSMITTED.

Consider the s.s.b. signal when the audio frequency signal varies

IF THE FREQUENCY VARIES
WITH 'm' CONSTANT.

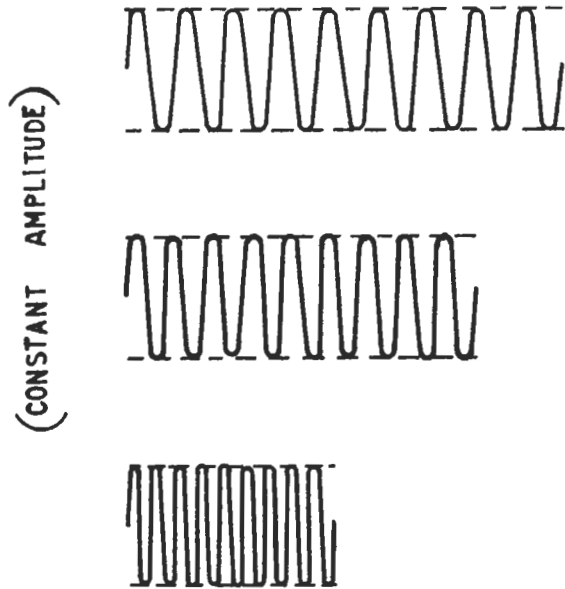

IF THE AMPLITUDE VARIES
i.e. 'm' VARIES WITH
f CONSTANT.

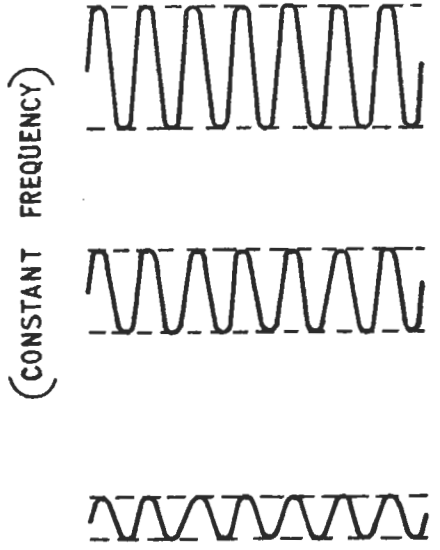

Diag. 3.7

Under speech signal conditions the sideband signal will therefore be varying both in frequency and in amplitude.

The human voice produces a complex waveform that can be represented by numerous frequency components of various amplitudes and various instantaneous phase relationships. No human voice is exactly like another voice, but statistical averages concerning the frequencies and amplitudes in the human voice can be determined.

The average power level of speech is relatively low when compared to the peak power level. An audio frequency waveform of an a sound is shown in diagram 8(a). The same a sound is shown in diagram 8(b) raised in frequency as it appears as an s.s.b. signal. From the shape of these waveforms, it is evident that the peak power, which is related to the peak voltage of a waveform, is considerably higher than the average power.

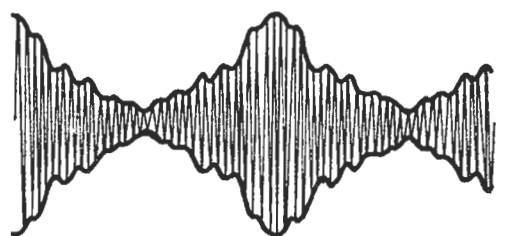
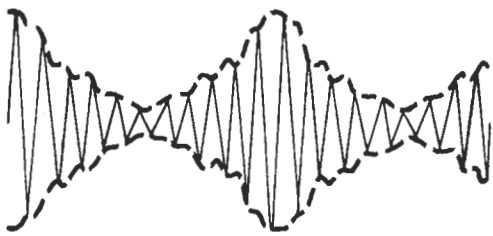

VOICE SIGNAL AT AUDIO FREQUENCY

S.S.B. VOICE SIGNAL

Diag. 3.8 (a)

Diag. 3.8 (b)

Overall transmission efficiency depends upon the average power transmitted, while transmitter power is limited to the peak power capability of the transmitter. Therefore for voice transmission, it is obviously beneficial to use speech processing circuits which will increase the average power in the voice signal without increasing the peak power. This can be done in several different ways, and in practice a combination of several methods may be used.

1. By the use of automatic gain control circuits to keep the signal level as near maximum as possible, i.e. VOGAD circuits.
2. By emphasising the low power high frequency components of the speech signal and attenuating the high power low frequency components.
3. By clipping the power peaks.

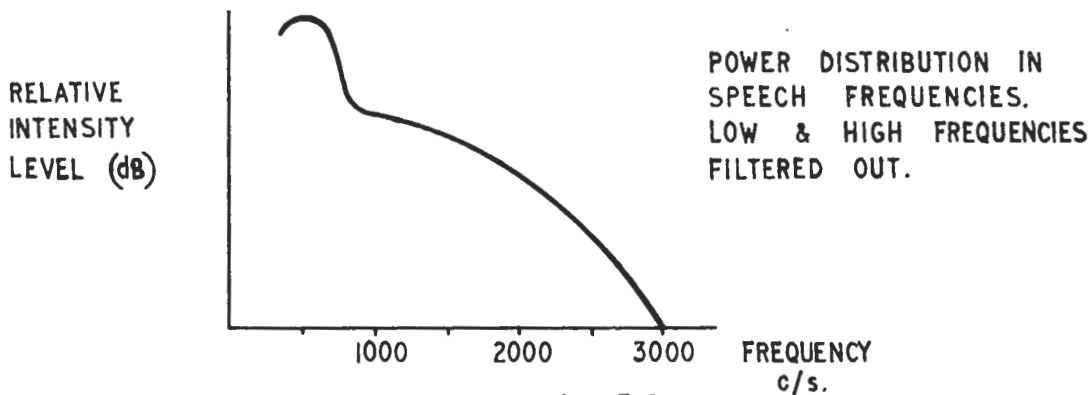

Diag. 3.9

The diagram 3.9 shows a power/frequency curve for the average human voice, after filtering below 200 c/s and above 3000 c/s. This curve shows that the high power components of speech are concentrated in the low frequencies. Fortunately, the low frequency components of speech contribute little to intelligibility, since these frequencies are concentrated in vowel sounds. The low frequencies may therefore be attenuated without undue loss of intelligibility of speech.

The low power high-frequency components present in a voice signal can be pre-emphasised to increase the average power of the signal. Since it is the high-frequency components which predominate in the consonant sounds, some emphasis of the high frequencies will improve intelligibility. However, to emphasise the high frequencies sufficiently to raise the average power level significantly would require compatible de-emphasis at the receiver to prevent loss of fidelity.

Clipping power peaks results in flattening the waveform at the clipping level and with severe clipping the s.s.b. signal becomes a series of square waves. Transmitting a square wave at a radio frequency imposes severe requirements on any transmitting system. This is true because the square wave is composed of an infinite number of odd harmonics of the fundamental frequency of the square wave. Therefore to transmit such a signal without distortion requires an infinite bandwidth. This is, of course, impossible because tuned circuits will not pass an infinite bandwidth. In an s.s.b. system where all frequencies are present it is found that the s.s.b. signal requires infinite amplitude as well as infinite bandwidth. This occurs because the fully clipped audio signal contains a large number of harmonics which give rise to sideband terms not in harmonic relationship. Because of the precise phase relationship of the audio harmonics, the sideband terms run in phase at a periodic rate equal to half that of the fundamental audio frequency. This phasing of the sideband terms results in an envelope peak that can be very large, as much as 8 dB above the normal signal level, which would overload the associated transmitter.

Let the modulated wave be represented by the expression:-

$$A_1 \sin \omega_m t \text{ where f.m. is the modulating frequency.}$$

If this waveform is clipped and approximates to a square wave, the equation of the wave becomes:-

$$A_1 \sin \omega_m t + A_2 \sin 3\omega_m t + A_3 \sin 5\omega_m t + \dots$$

fundamental + 3rd harmonic + 5th harmonic + ...

This clipped audio frequency is now translated up to a radio frequency and becomes:-

$$A_1 \sin (\omega_c + \omega_m)t + A_2 \sin (\omega_c + 3\omega_m)t + A_3 \sin (\omega_c + 5\omega_m)t$$

(where ω_c = carrier frequency).

Let the first term be the reference vector and assume it to be stationary.

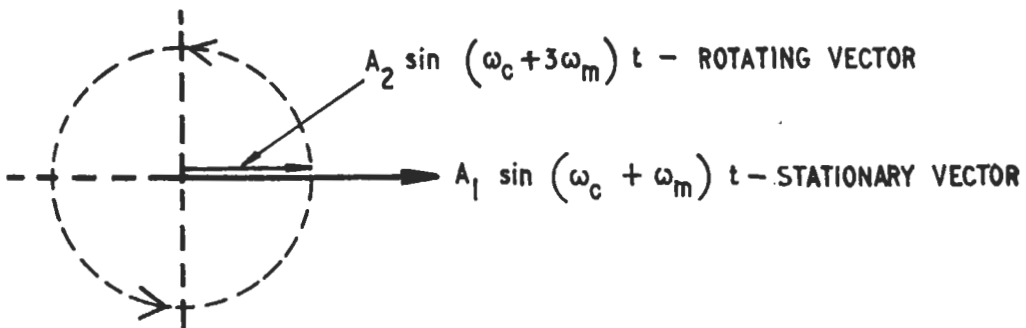

Diag. 3.10

The rotating vector rotates at a velocity = $2\omega_m$, with respect to the stationary vector. This means that it will be in phase again with the stationary vector after a time interval of $\frac{T_m}{2}$ seconds where T_m is the periodic time of the modulating frequency f.m.

Likewise the next term, $A_3 \sin (\omega_c + 5\omega_m)t$ will be rotating at twice the speed of the previous vector $A_2 \sin (\omega_c + 3\omega_m)t$ and will be in phase with the other two vectors every second revolution, i.e. $\frac{T_m}{2}$ seconds. Under these conditions the terms will add to infinity, every $\frac{T_m}{2}$ seconds, i.e. at a periodic rate equal to half that of the fundamental audio frequency.

Production of the S.S.B. Signal

The present generation of Transmitters and Receivers, i.e. the 600 Series Transmitter and the B40 Receiver, operate on basic and well known principles. The transmitter is anode modulated for voice and keyed by overbias, it produces a standard double sideband signal either keyed c.w., modulated c.w. or voice. The receiver is a normal superhet with modifications in the b.f.o. to ensure satisfactory reception of f.s.k. transmissions.

The next generation of transmitters produces a single sideband signal that can be modulated in a variety of ways to ensure that the available spectrum space is used to the best advantage. The frequency stability of the output is very much better than the 600 series which means that the frequency stability of the associated receiver must also be improved.

S.S.B. Transmitter

The block diagram shows an early s.s.b. transmitter. As this transmitter derives its radiated frequency from a crystal oscillator and not from a frequency standard and frequency synthesiser, a pilot carrier will be transmitted. The frequency stability is not sufficiently good for the carrier to be completely suppressed. The receiver will also require an effective Automatic Frequency Control to enable it to lock on to the pilot carrier and then amplify it for demodulation. (See Chapter 9).

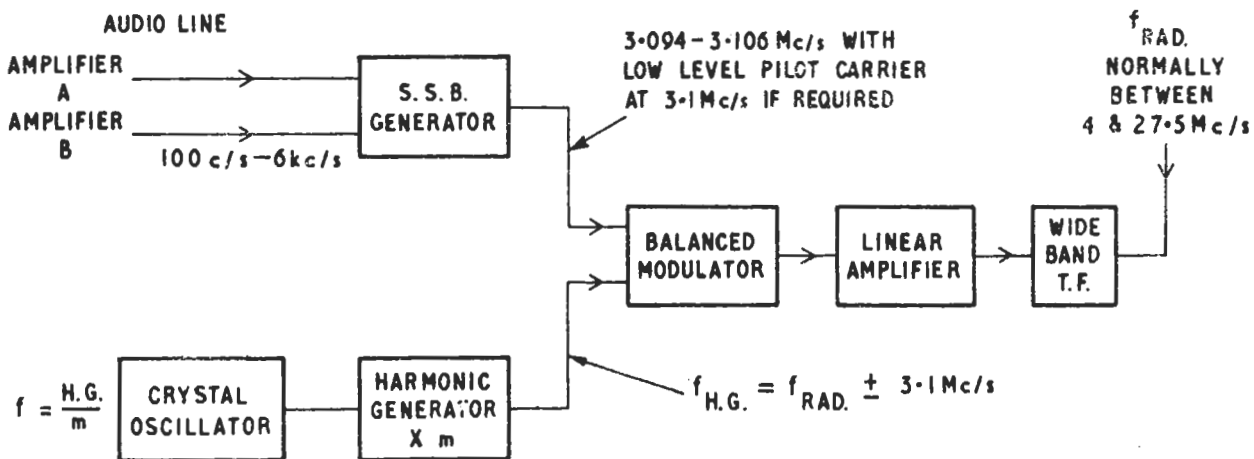
S.S.B. DRIVE UNIT

Diag. 3.11

Primary Drive Unit: Use the + sign when $f_{RAD} < 10$ Mc/s

Use the - sign when $f_{RAD} > 10$ Mc/s

The s.s.b. generating equipment, commonly called an s.s.b. drive unit accepts either of two separate audio inputs A and B and converts them to an Independent Sideband output. With non-synthesised equipment this output comprises a low level pilot carrier at 3.1 Mc/s skirted by an upper sideband from 3.1001 Mc/s to 3.106 Mc/s and a lower sideband from 3.0999 Mc/s to 3.094 Mc/s.

The level of the pilot carrier is made as low as possible, so that maximum possible power is available for the intelligence bearing sidebands and to reduce interchannel cross-talk to a minimum. The level must, however, be sufficient to maintain a signal to noise ratio in the carrier channel at the receiver, consistent with the signal to noise ratio in the sideband.

The 3.1 Mc/s plus or minus the tones from the s.s.b. drive unit is applied to the Balanced Modulator together with the Primary Drive from a crystal controlled oscillator and harmonic generator. For values of radiated frequency f_{RAD} below 10 Mc/s the positive sign is used and for frequencies above 10 Mc/s the negative sign is used.

e.g. if $f_{RAD} = 6.0$ Mc/s
 then $f_{HG} = 6.0 + 3.1 = 9.1$ Mc/s
 if $f_{RAD} = 20$ Mc/s
 $f_{HG} = 20 - 3.1 = 16.9$ Mc/s.

This convention has been standardised on s.s.b. HF links.

It should be noted that channel A is radiated on the high frequency side of the pilot carrier for values of f_{RAD} above 10 Mc/s and on the low frequency side for values of f_{RAD} below 10 Mc/s.

The output from the balanced modulator is then passed to the linear power amplifier to be amplified to the required power output. The output from the amplifier is then fed via a matching transformer to the aerial circuits.

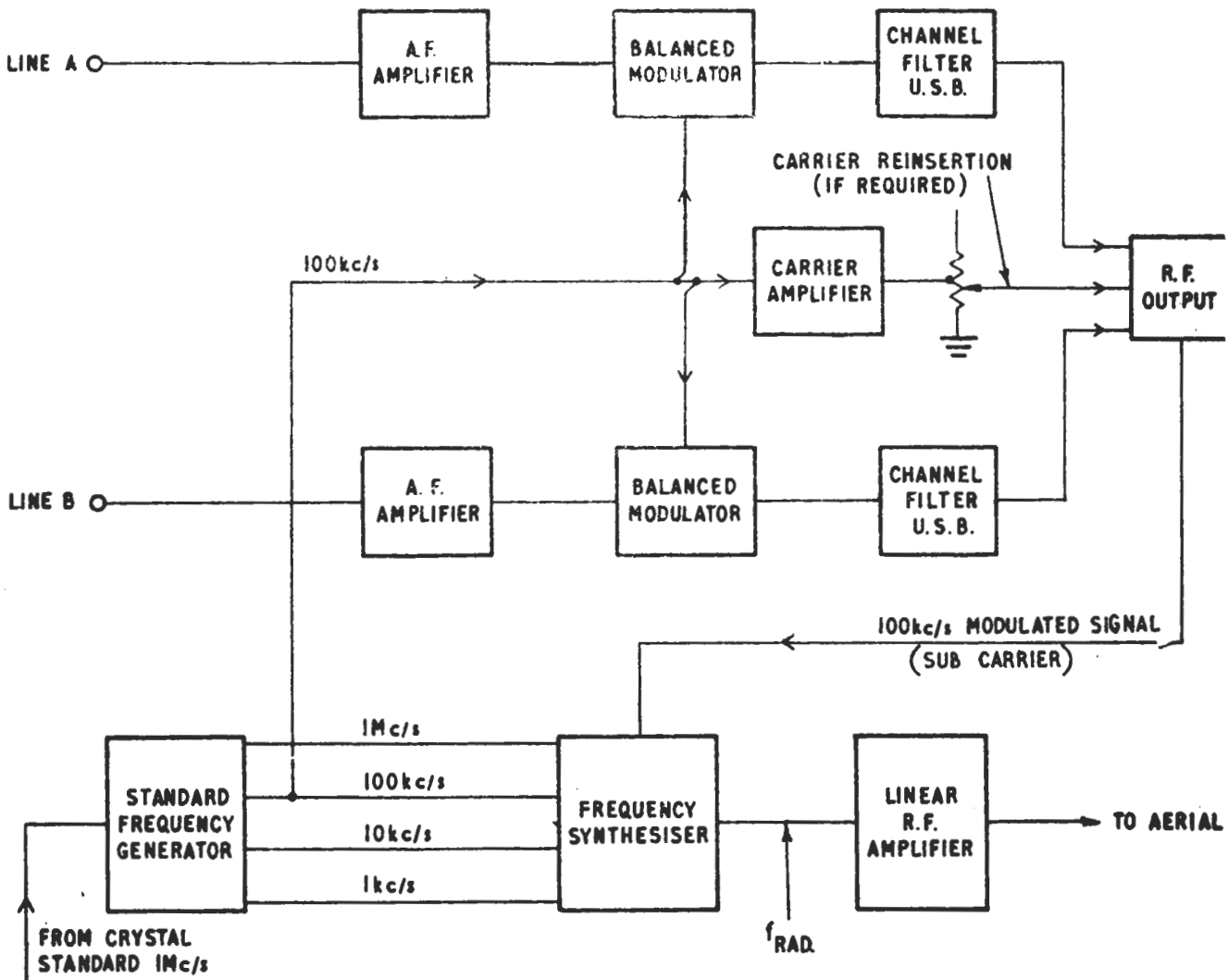

Diag. 3.12

The block diagram shows the basic requirements of a modern s.s.b. transmitter. There are several new techniques here, which will be described in some detail later.

The first thing that must be realised, is that modulation is now carried out at a relatively low frequency, the sub-carrier, usually 100 or 300 kc/s, and at a low power. Nearly all s.s.b. drive units use a Balanced Modulator in one form or another and this circuit will now be described in more detail.

Balanced Modulators to produce an S.S.B. Signal

Modulation or frequency translation is obtained by combining the a.f. signal and the carrier in the modulator and so obtaining the sidebands. The carrier signal itself will be cancelled out (diagram 3.6) and the unwanted sideband removed by filtering, leaving the wanted sideband to be applied as a sub-carrier to the frequency synthesiser. The output from the synthesiser will be a s.s.b. signal

There are many types of modulators, but they can be grouped into three main functional divisions

1. Rectifier Modulators
2. Multielectrode valve Modulators
3. Non-linear Reactance Modulators

Rectifier Modulators

These have several advantages which make them particularly suitable for s.s.b. generation. Their great advantage is high stability compared with valve modulators. They require no heater supply, they are compact, have a long life and require no maintenance.

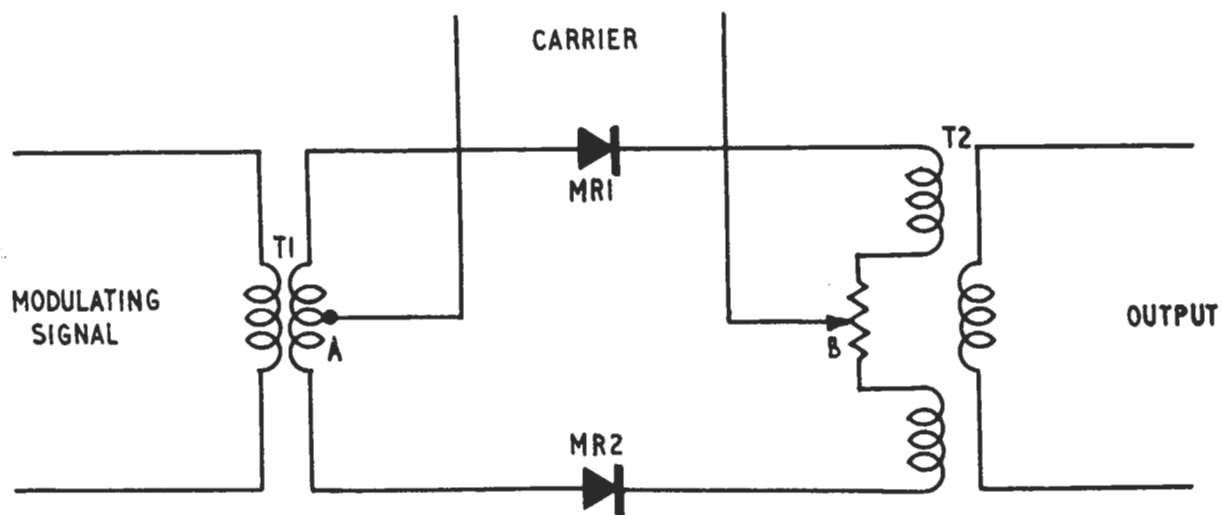

Diag. 3.13

A typical series modulator is shown in the diagram 3.13. The carrier is applied between the centre taps of the two transformers and provided that the diodes are correctly matched no carrier frequency oscillation will reach the output of T_2 . It is usual to incorporate a carrier leak potentiometer for balancing out the carrier currents in the two halves of T_2 to obtain minimum carrier output.

The impedance of the diodes MR1 and MR2 varies according to the bias applied, being quite small when the diodes are forward biased and very large when back biased. The carrier input is arranged to be of considerably greater amplitude than the modulating signal and therefore controls the bias. On half cycles of carrier voltage when A is of higher potential than B, the diodes are forward biased and a low impedance path is set up between T_1 and T_2 . During the other half cycles, when B is at a higher potential than A, the diodes are back biased and the impedance between T_1 and T_2 is high, thus blocking the signal path.

The input and output waveforms are shown in diagram 3.14 and although the output waveform appears to show no resemblance to the anticipated waveform of diagram 3.6 this is due to the presence of a large number of frequencies, including a modulating signal component, in addition to the upper and lower sidebands. The output waveform follows the modulating signal input during the positive half cycles of the carrier, but is zero during the negative half cycles.

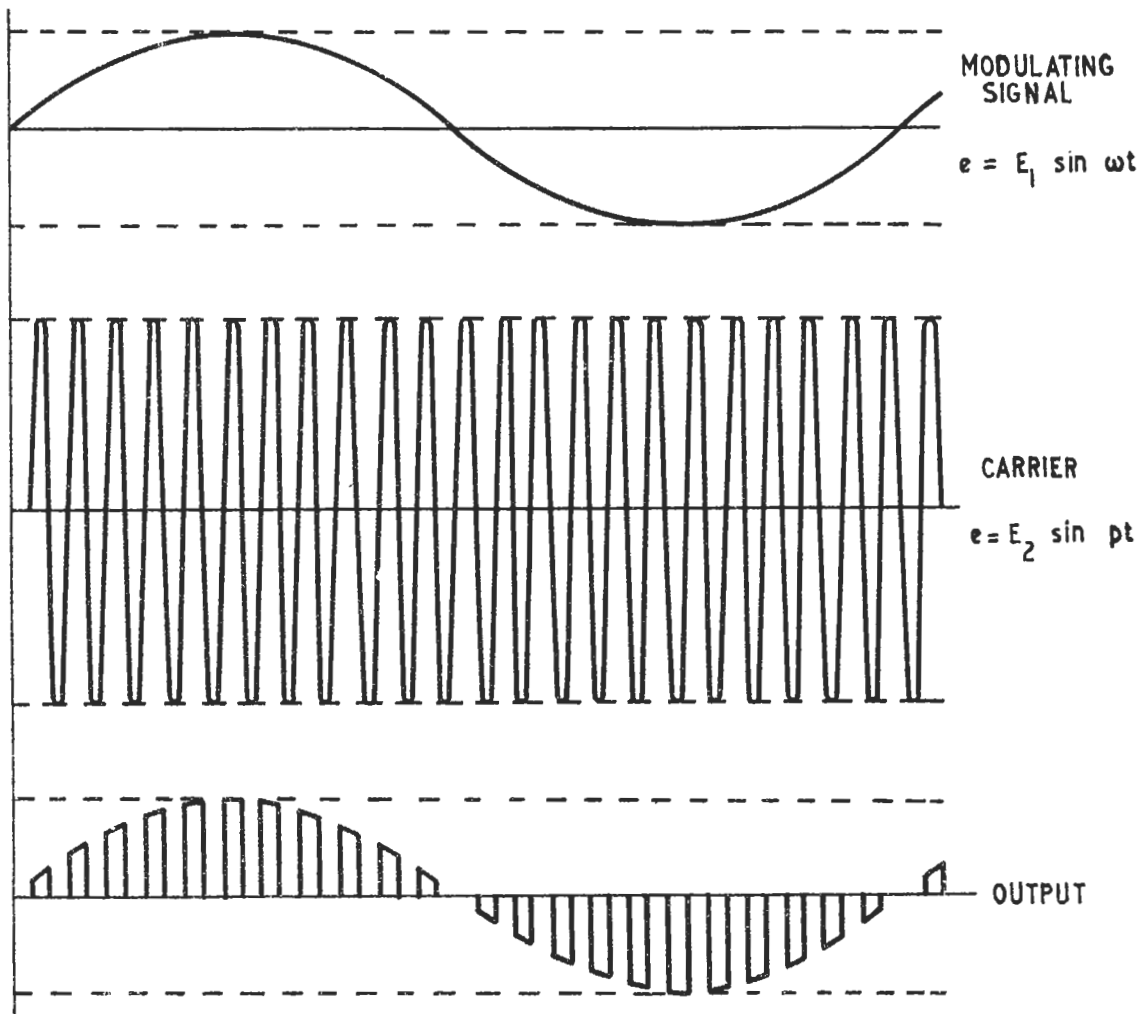

Diag. 3.14

The output signal is equivalent to the input modulating signal multiplied by a square wave.

In the double-balanced bridge ring modulator, the carrier is suppressed in a similar manner to that employed in the circuit of diagram 3.13 but the modulating signal is also suppressed by arranging the four diodes in bridge form and applying the modulating signal across one diagonal as shown in diagram 3.15. The same circuit drawn in lattice is also given and either form may be encountered in circuit diagrams. This circuit gives an output comprising the upper and lower sidebands free of both modulation and carrier frequencies.

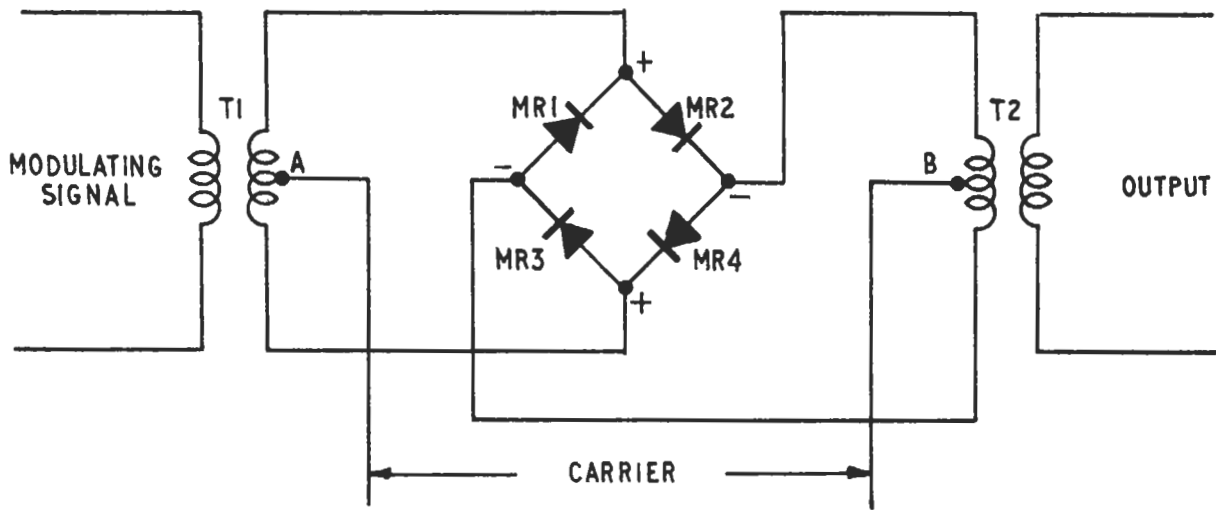

OR ALTERNATIVELY

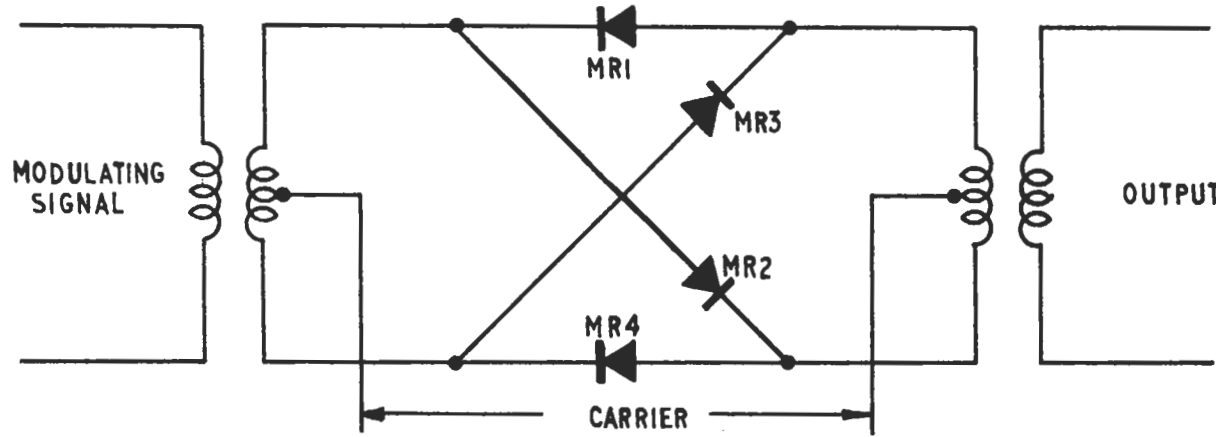

Diag. 3.15

As before, the carrier amplitude must be large compared with the modulation. When A is at a higher potential than B, the diodes MR2 and MR3 being forward biased will offer a low impedance path, whilst MR1 and MR4 being back biased offer a high impedance. On the other half cycle the conditions are reversed, diodes MR2 and MR3 being back biased and MR1 and MR4 forward biased. The signal path between T₁ and T₂ is therefore reversed after each half cycle of carrier and, since the carrier frequency is greater than the frequency of the modulating signal, this reversal occurs several times during each cycle of the modulation. The input and output waveforms are given in diagram 3.16 and it will be seen that the output waveform is again equivalent to the input modulating signal multiplied by a square waveform and is similar to that obtained for the single balanced circuit. However, the modulation frequency is no longer present and the sidebands have twice the amplitude, indicating that an improvement in the output is obtained from the use of the double balanced circuit.

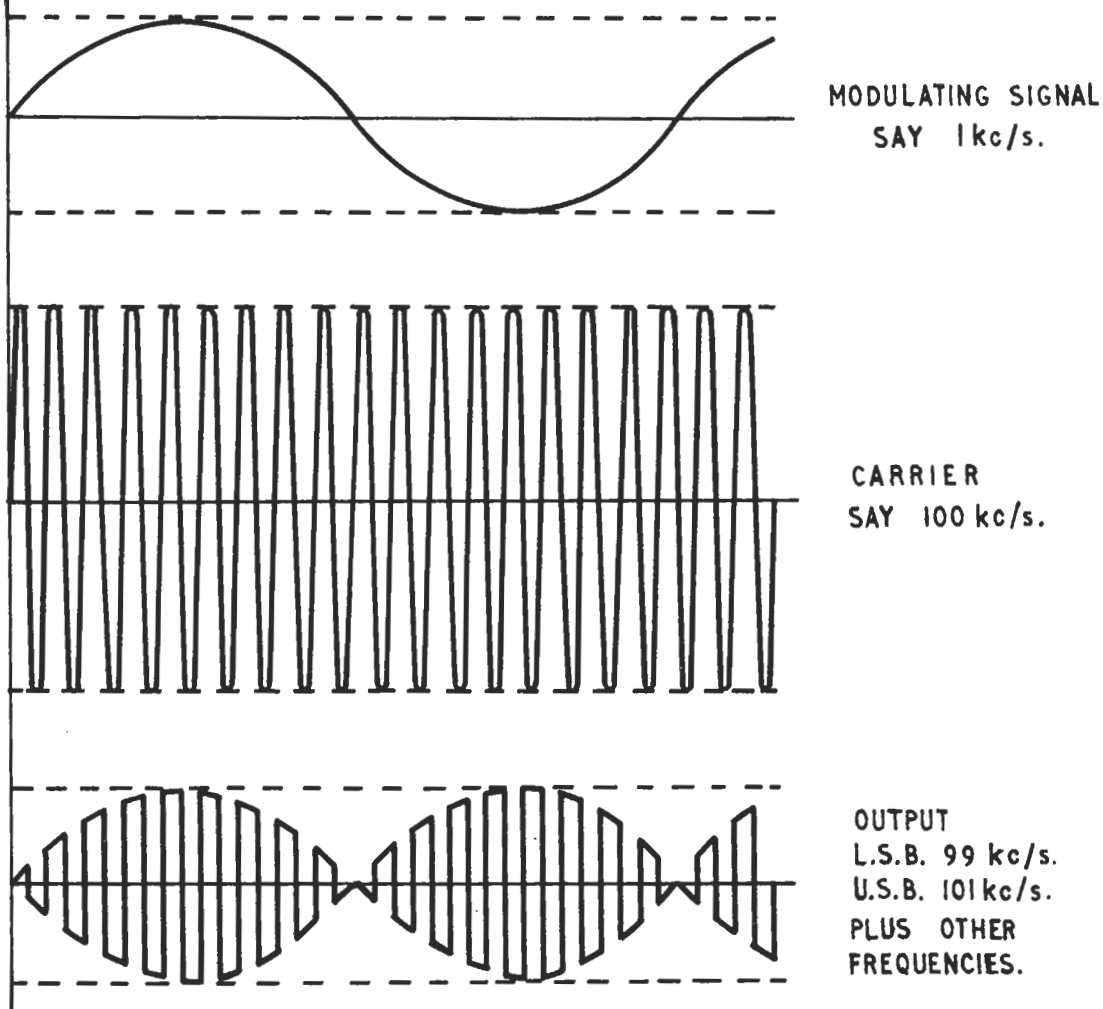

Diag. 3.16

There are a number of modulators designed to operate in the "switch" mode, the circuit variations usually give the unit some particular advantage over the standard circuit. One of the circuits in its single form is shown in diagram 3.17.

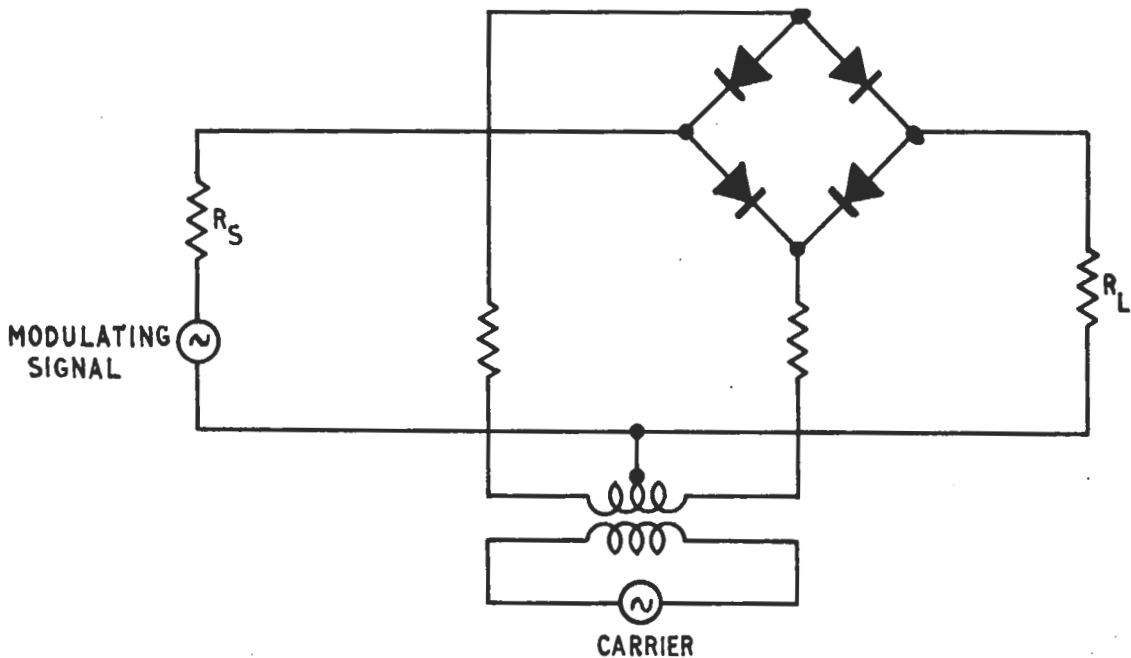

The carrier is at a higher level than the modulating signal and switches the four diodes on and off on alternate half cycles of the carrier. The signal path between the source and the load is thus made or broken on alternate half cycles of the carrier and the output waveform is as shown in diagram 3.17.

Valve Balanced Modulators (Diagram 3.18)

The operation of these modulators is well known. The audio input can be connected in push pull with the r.f. drive in parallel, the output of the two valves connected in push pull. Balanced modulators can also be connected with the r.f. drive and audio inputs in push pull and the output, in parallel. The choice of a balanced modulator circuit is generally determined by constructional considerations and the method preferred. Normally two valves of the same characteristics can be adjusted to give at least 30 dB of carrier suppression. Since in suppressed carrier single sideband transmission it is desirable to suppress the carrier at least by 40 dB, the selective filter following the balanced modulator is used for further carrier suppression.

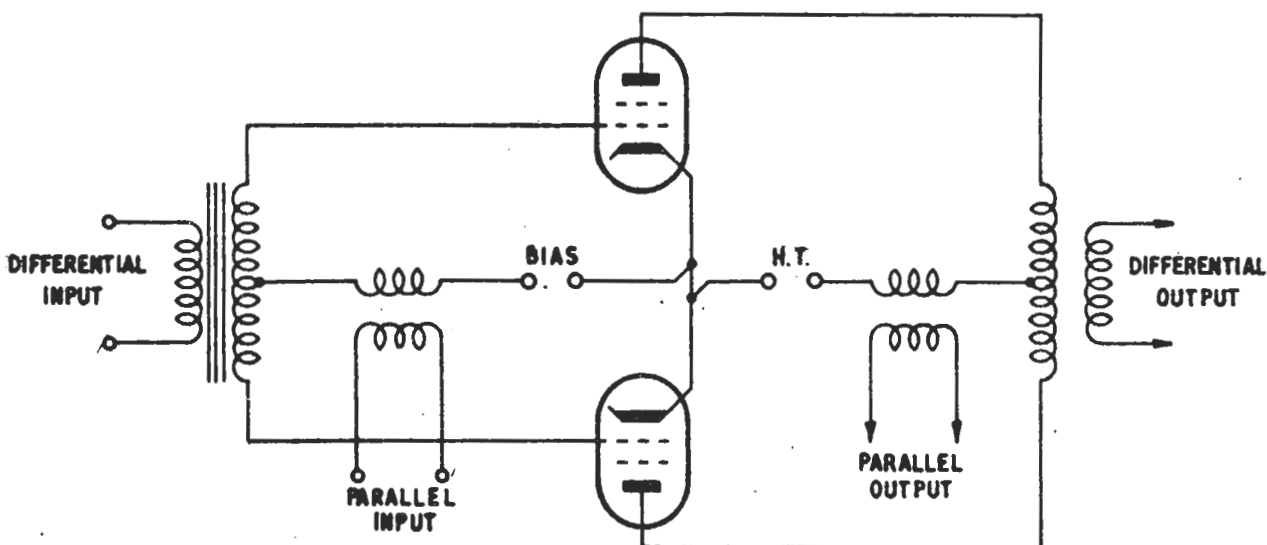

Diag. 3.18

If the inputs are at different frequencies, f_1 and f_2 and the valves are operated under class B or C conditions so that harmonic frequencies are generated; the outputs will be:-

	Differential i/p	Parallel i/p	Differential o/p	Parallel o/p
(a)	f_1	nil	f_1 and odd harmonics of f_1	Even harmonics of f_1
(b)	nil	f_1	nil	f_1 and all harmonics of f_1
(c)	f_1	f_2	$f_1 + f_2$ $f_1 - f_2$ f_1 and odd harmonics of f_1	f_2 and all harmonics of f_2 Even harmonics of f_1
(d)	$f_1 + f_2$	-	f_1 f_2 Odd harmonics of f_1 and f_2	$f_1 + f_2$ $f_1 - f_2$ Even harmonics of f_1 and f_2

The most common mode of operation is (c) where the modulating frequency f_1 is applied differentially and the carrier frequency f_2 is applied in parallel. The output circuit will be connected differentially so that there are in the output: $f_1 + f_2$, the upper sideband; $f_2 - f_1$, the lower sideband but no component of carrier frequency f_2 .

Non-Linear Reactance Modulators

Ferrite cores are now being used in modulator circuits as shown in diagram 3.18.

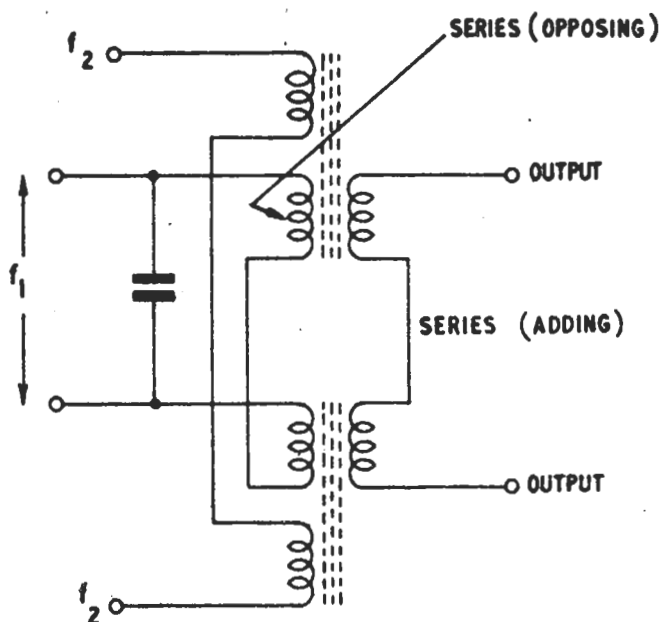

Diag. 3.19

If a voltage is applied at a frequency f_1 of sufficient amplitude to saturate the ferrite cores of the transformers there will be no output (125 mW is sufficient for saturation).

If another frequency f_2 is now applied there will be several output frequencies, amongst these will be $2f_1 + f_2$ and $2f_1 - f_2$.

Therefore, if f_1 is 50 kc/s and f_2 is an a.f. of 1 kc/s the output will be 101 kc/s and 99 kc/s with complete suppression of the 100 kc/s or carrier frequency.

Sideband Generation

A single sideband can be obtained by passing the output of a balanced modulator (carrier suppressed) through filter circuits that are sufficiently selective to transmit one sideband while suppressing the other. The requirements that the filter must meet are rather severe, thus if the lowest modulating frequency is 100 c/s, the filter characteristic must change from full transmission to very effective rejection in a frequency range of $2 \times 100 = 200$ c/s. Even with well designed filters, very high Q values are required to give such sharpness of discrimination. This means that it is practical to modulate at a relatively low r.f. where such filters can, more easily, be designed. The sideband on a sub-carrier is then frequency translated to the required frequency of radiation. In many systems modulation is carried out at a sub-carrier frequency of 50kc/s, 100kc/s or 300 kc/s and then translated to the required radiated frequency in the frequency synthesiser.

Having produced a single sideband signal at the correct frequency for radiation it must be power amplified before application to the aerial. The s.s.b. signal must be amplified without distortion and this means that all the power amplifiers must be linear. In modern systems most of the amplifiers will be operated under class A or class AB. Some efficiency must therefore be sacrificed when a comparison is made with the class C d.s.b. system. However, the advantages of the s.s.b. system far outweigh its disadvantages. Linear power amplifiers will be dealt with in detail in later chapters.

Definitions

In s.s.b. operation only one sideband frequency is transmitted for each modulation frequency applied to the audio input, instead of two sidebands as in the case of the d.s.b. system. As a result, the sideband regions above and below the nominal radiated carrier frequency may be used to carry different information, giving what is known as independent sideband operation or I.S.B.

Channel. It will be found that in the literature dealing with s.s.b. operation, the term "channel" is used in various ways. An s.s.b. transmitter using the upper and lower sidebands to convey different signals is spoken of as a two channel transmitter as well as an independent sideband transmitter. The agreed Inter-Service definition is "A means of communication suitable for connection to instruments switchboards, or the like". The G.P.O. definition is "A means of one way communication".

In radio telegraphy it is quite normal to arrange for a number of intelligence channels to be conveyed on one radio path or circuit.

A system - All equipment, lines and jackfields between the terminal bay equipment at one end of a communication channel and the terminal bay equipment at the other.

Simplex working - A method of working in which telecommunication between two stations takes place on one frequency, in one direction at a time.

Duplex working - A method of working in which telecommunication between two stations takes place in both directions simultaneously.

Multiplex - The name given to any method which enables the transmission of two or more independent traffic channels simultaneously over one line or radio circuit.

Frequency division multiplex - In this method the total bandwidth available on the circuit is shared between the traffic channels, each channel has continuous and exclusive use of its allocated frequency band.

Time division multiplex - In this method each channel is allocated exclusive use in turn of the complete circuit for part of the time.