

Introduction

There are two basic methods of modulating an r.f. wave represented by the equation  $A \sin \omega_c t$ . Either  $A$ , the amplitude, may be varied in response to the modulating signal or  $\omega$ , the angle, may be varied. The first method is known as amplitude modulation and the second as angle or frequency modulation. There are many variants of the two main groups.

A distinction must also be drawn between primary and secondary modulation. For example a Transmitter may be amplitude modulated by a Tone which itself may be keyed ON/OFF (A.M.) or shifted in frequency (F.M.) in response to the secondary modulation. It will be shown later that many such systems are in use. It will also be shown that in some cases the resultant output "on the air" may be obtained by more than one method.

At all times we are concerned with two types of modulation - analogue modulation, i.e. speech, and digital modulation i.e. RATT.

Primary Modulation Methods

The simplest type of amplitude modulation is where the r.f. wave is switched ON/OFF in response to a flow of digital information. This type of "keying" - which is another word for modulation - is known as "c.w." - continuous wave, or more correctly "ON/OFF" keying.



Diag. 2.1

This is still a widely used form of keying using the morse code. Its use in the service includes ship/shore working, secondary broadcast and a limited use on Tactical circuits. The main disadvantage of this system is that the signal/noise ratio is zero during the spaces. This has prevented its use for modern systems such as RATT. However, the system has one very great advantage in that a good operator can read a message through noise, that would preclude the use of automatic equipment. A further advantage is that the equipment required is so simple. Service equipments using this system are the 600 series transmitter and the B40 receiver.

This system has the further disadvantage that the regulation of the transmitter is difficult and there is a great lack of protection against fading and impulsive interference at the receiver.

Using modern sinewave keying, the bandwidth can be reduced to a value not much greater than the keying speed in bands i.e. 100 c/s. The wave shape required can be transmitted by the fundamental and the 3rd harmonic of the keying frequency.

Filter design prevents this ideal state being realised and it is customary to take a bandwidth of four times the keying frequency (2 x Band speed).

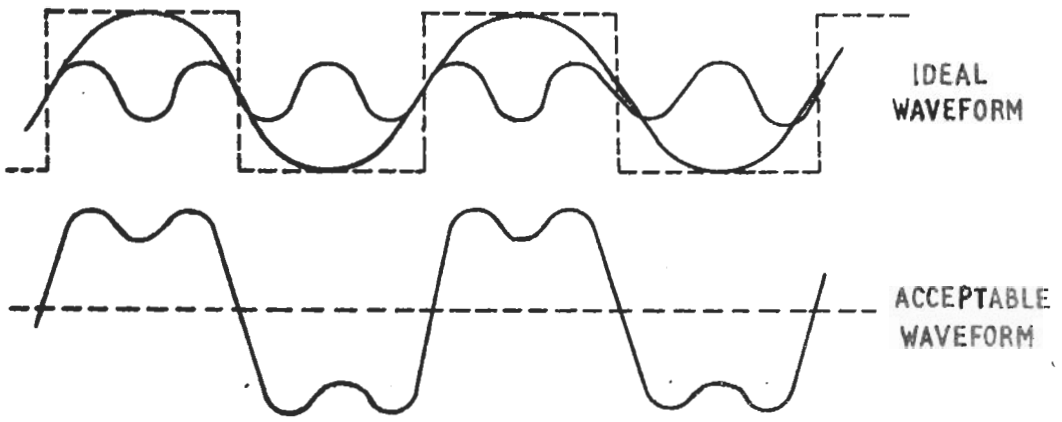

Diag. 2.2

D.S.B. A.M. Double Sideband Amplitude Modulation

This type of modulation is the simplest form of the analogue type. The amplitude of the carrier varies proportionally to the instantaneous value of the modulating waveform, which may be simply a tone, a number of tones or a complicated speech waveform.

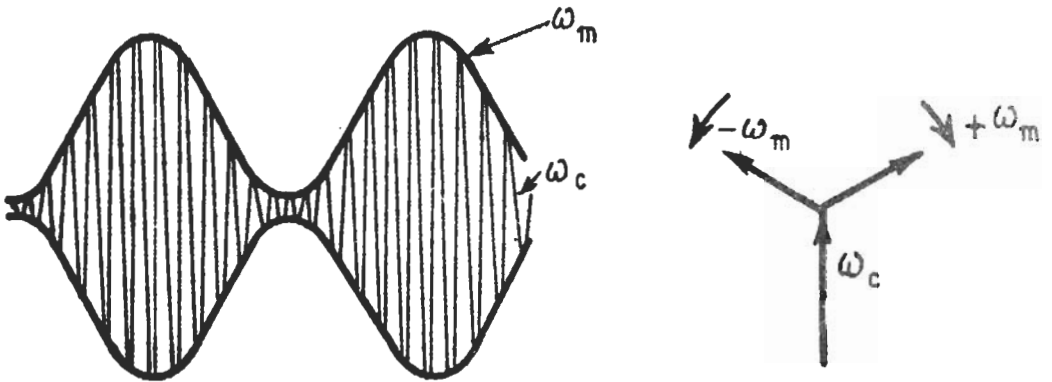

Diag. 2.3

This waveform may be represented by the three vectors ( $\omega_c + \omega_m$ ),  $\omega_c$  and ( $\omega_c - \omega_m$ ). This gives rise to the radiation of the carrier frequency and two sidebands. This is dealt with in detail in the SSB section.

It can be seen that this system has a bandwidth that is twice the highest modulating frequency.

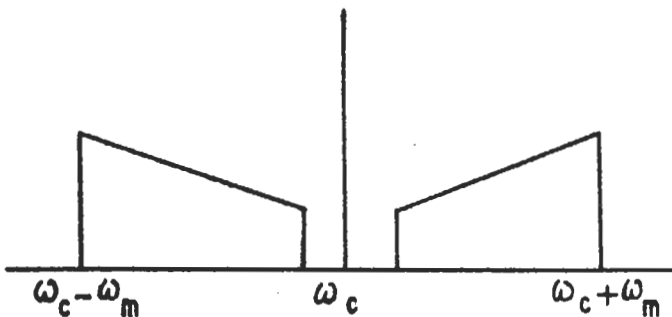

Diag. 2.4

The main disadvantages of this system are the wastage of power in one sideband and the carrier together with the poor utilisation of the bandwidth. The transmission of the continuous carrier causes, and is subject to, severe adjacent channel interference in the form of whistles. A further major disadvantage is the effect of selective fading on the carrier. This is dealt with in later chapters.

## Modulated C.W. (M.C.W.)

This form of keying is a combination of a.m. and ON/OFF keying. It consists of a single tone modulating (a.m.) a carrier. The two being keyed ON/OFF in response to the keying stream.

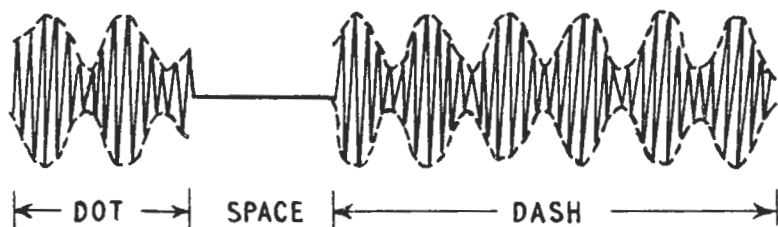

Diag. 2.5

In some systems the carrier is left on and only the tone switched ON/OFF in response to the key stream. This may be likened to the single tone version of the two tone system currently in use for RATT working in UHF.

The main advantage of m.c.w. is that no b.f.o. is required. The system is now mainly used for distress working and enjoys a certain immunity from interference as the actual tone heard is constant and does not depend on b.f.o. setting. In the past many crude methods of modulation have been employed. One method was the use of unsmoothed h.t. in the transmitter. This system was always unpopular due to the excessive bandwidth and waste of power in the unwanted sideband and carrier.

## Frequency Modulation

In this type of modulation, the instantaneous frequency of the radio frequency wave is varied in accordance with the signal to be modulated on the wave, while the amplitude of the radio frequency wave is kept constant. This results in a waveform of the type shown in the diagram.

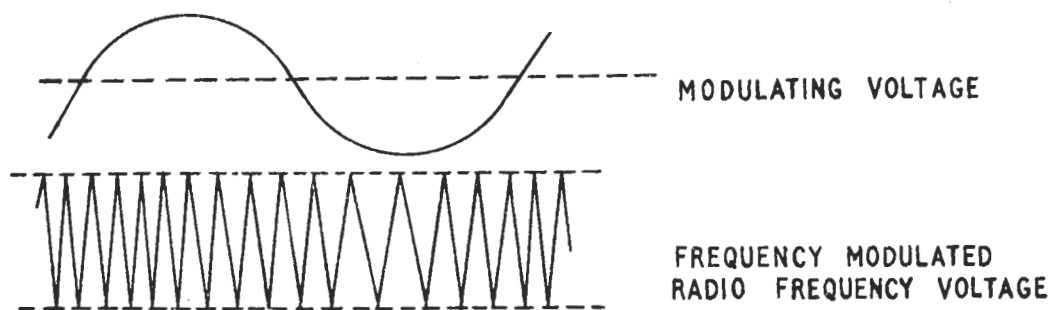

Diag. 2.6

Here the number of times per second that the instantaneous frequency is varied about the average (or carrier frequency) is the modulating frequency, while the amount that the frequency varies away from the average, called the frequency deviation 'm', is proportional to the amplitude of the modulating signal.

At first sight it might seem that intelligence could be transmitted by frequency modulation with an extremely narrow bandwidth, unfortunately this is not so and a frequency modulated wave can be shown to have not only the same frequency components as does an amplitude modulated wave, but higher order sidebands as well. The complicated sideband pattern has precluded the use of frequency modulation for service use except in one or two isolated equipments and has also meant that in broadcasting use has had to be made of VHF in order not to crowd the already congested HF band.

## Telegraph Modulation Methods

Telegraph modulation is the process by means of which the telegraphic information is impressed on the radio frequency carrier.

Although there are still quite a number of "ON/OFF" (c.w.) telegraph modulation systems in operation, Frequency Shift Telegraphy (f.s.t.) is now firmly established as the preferred method and will eventually replace ON/OFF systems completely. Sharing just about equal popularity with the f.s.t. methods are "Voice Frequency" telegraph systems. These will be dealt with more fully later.

### ON/OFF Keying

This is obviously the simplest method of digital modulation and was dealt with earlier in this chapter.

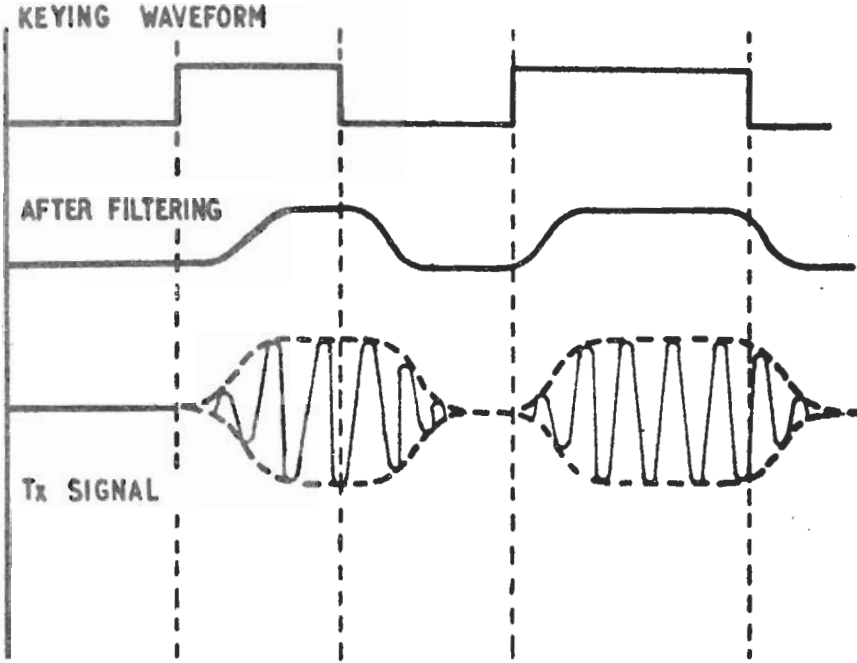

Diag. 2.7

Using modern sine wave keying the bandwidth can be reduced to a value not much greater than the keying speed in bauds. The keying waveform is filtered to round off its edges and then applied as modulation to the transmitter. Modern "ON/OFF" systems when accurately set up will give very good results.

For the demodulation of "ON/OFF" signals, an envelope detector is often employed. A type known as the "Slideback" detector is very popular as it will maintain an output balanced about earth potential, even under fading conditions.

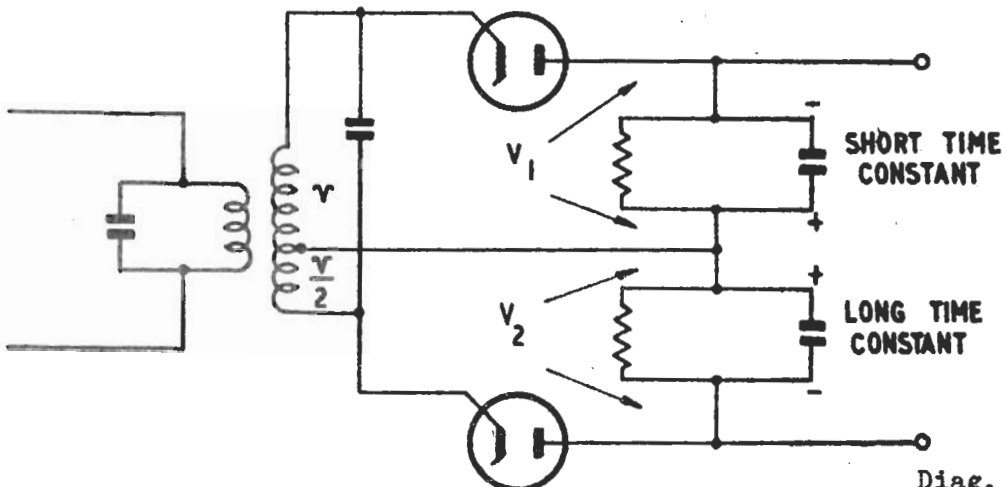

Diag. 2.8

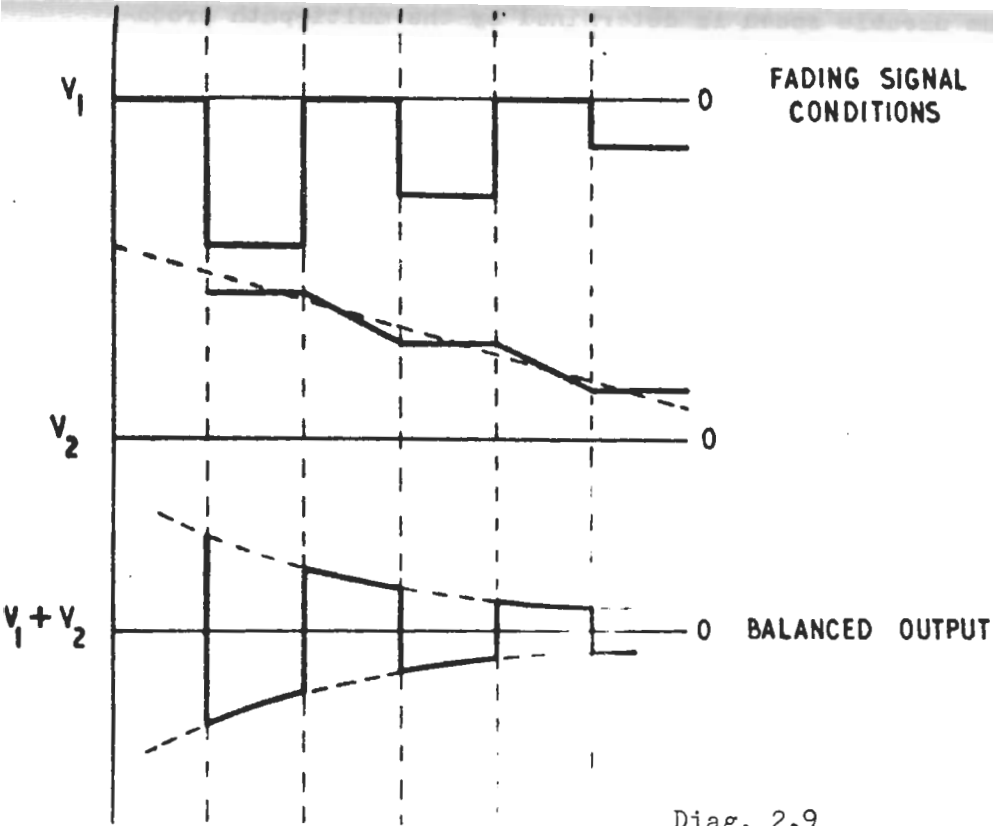

Diag. 2.9

The balanced output is a big advantage when using machines.

### Diversity Reception

All HF communications circuits are subject to fading and to reduce errors caused by fading diversity is commonly used. Two receivers are fed from a pair of aerials spaced a number of wavelengths apart. Fading at an aerial is unlikely to occur at the same instant as fading at the other. The output is taken from the receiver having the stronger signal at any instant. Any number of diversity paths may be employed but the improvement is not directly proportional to the number of paths.

### Frequency Diversity

This can be employed in ships. The same information is transmitted and received on two or more frequencies simultaneously. The two or more frequencies will not fade at the same instant. Frequency diversity can be simulated in a single frequency system by modulating the keyed carrier at an audio frequency - usually 400 c/s. Amplitude, frequency or phase modulation may be used. The object is to set up sideband components, each of which carries the keying information and will not all fade at the same instant.

### Frequency Shift Telegraphy

This is a frequency modulation method. The carrier is frequency modulated on to one of two frequencies: the 'Z' or IDLE frequency and the 'A' or ACTIVE frequency. The separation of the two is called the Frequency Shift.

For maximum information rate the keying speed should be a maximum.

For minimum bandwidth, both the keying speed and the frequency shift should be a minimum.

Increasing either keying speed or frequency shift will increase the bandwidth. An increase in speed has a smaller effect on bandwidth than a similar increase in shift. Therefore where possible maximum speed and minimum shift should be used.

The maximum useable speed is determined by the multi-path propagation effects. If a code element is of too short a duration it may be received as two or more pulses due to propagation via paths of different delay times. The maximum speed for HF systems is limited to between 100 and 200 bauds.

The minimum useable frequency shift is determined by the frequency stabilities that may be achieved and the feasibility of designing the necessary filters.

The present Naval frequency shift at HF is 850 c/s as used on broadcasts and the speed used is 50 bauds. These can be improved considerably and modern recommendations are:-

Speed	Bandwidth c/s		
	200 c/s shift	400 c/s shift	500 c/s shift
50 bauds	350	600	700
100 bauds	400	700	800
200 bauds	600	800	1000

Some Naval networks will be increasing their speed to 75 bauds in the near future.

Frequency shift keyed signals are normally demodulated by means of a frequency discriminator. This is preceded by a limiter and followed by a low pass filter.

#### Multi-Channel F.S.T. Telegraphy

Teleprinters operate at a keying speed of 50 bauds. As the optimum speed over the radio link is between 100 and 200 bauds; Time Division Multiplexing of two or four channels is employed. Element or character interleaving can be used or, in the 4 channel system, a combination of both. The synchronous operation of transmitter and receiver is essential. Channel B and Channel C in the 4 channel mode are inverted as a means of identification. This also has the secondary advantage of giving the same number of marks and spaces in any 14 element aggregate group (any 28 in a 4 channel system). This guarantees a constant number of transitions per aggregate group for synchronising purposes.

As an example, using 2-channel 7-unit code

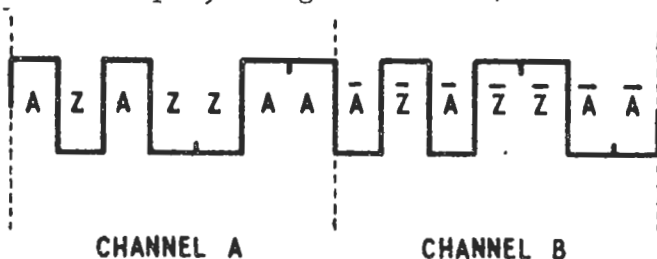

Diag. 2.10

Channel A is erect. Channel B is inverted.

## 4-channel output (192 baud)

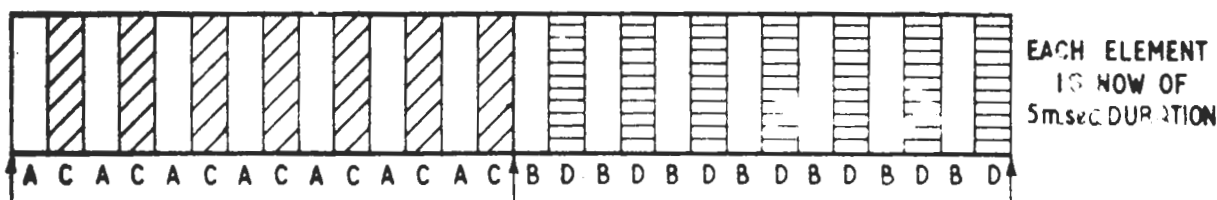

EACH ELEMENT  
IS NOW OF  
5msec DURATION

CHANNEL A ELEMENT  
INTERLEAVED WITH CHANNEL C

CHANNEL B ELEMENT  
INTERLEAVED WITH CHANNEL D

Diag. 2.11

Channels A and D are transmitted erect.

Channels B and C are transmitted inverted.

## Voice Frequency Telegraphy

As an alternative to time division methods of providing multi-channel telegraphy, frequency-division methods may be employed. The usual system is that known as Voice Frequency Telegraphy.

The channelised signal is generated in the audio frequency band, each channel occupying its own particular part of the spectrum. The aggregate signal is then applied, as modulation, to the transmitter. For point-to-point working an s.s.b. or independent sideband modulation method will be used.

Three different methods of keying a channel are possible: Single Tone keying; Frequency Modulated keying and Two Tone keying.

### Single Tone Keying

A number of audio oscillators of different frequencies are provided, one for each channel. Each oscillator is keyed in an 'ON/OFF' manner by a particular keying waveform. All the keyed tones are then added to form a multi-channel signal, this then modulating a telephone transmitter.

At the receiver the signal is demodulated in the normal manner and the keyed tones separated in a bank of channel selection filters. This system is not usually employed in modern radio systems.

### Frequency Modulated Voice Frequency (F.M.V.F.)

As in the case of single-tone keying, a number of audio tones are provided, one for each channel. Each audio tone is frequency shift keyed by a keying waveform, the outputs being added and the aggregate applied as modulation, to a telephone transmitter. Again, two methods of demodulation are possible. A separate single channel f.s.t. receiver suitably tuned can be used for each channel. Alternatively banks of channel selection filters may be used.

The number of channels that may be accommodated in a speech bandwidth of 3 kc/s depends on the minimum useable tone separation. This in turn is dependent on the attainable filter discrimination. Using tone separations of 170 c/s with frequency shifts of 85 c/s, up to sixteen 100 baud telegraph channels may be accommodated within the bandwidth of a normal telephone channel.

### Two Tone Keying

Two tone keying bears certain similarities to both single tone and the frequency modulation methods of V.F.T. Two audio frequency oscillators are provided for each channel, one generating a "Mark" frequency and the other generating a "Space" frequency. These two oscillators are ON/OFF keyed in anti-phase by the telegraph waveform, the resultant keyed signals being added together. The effect is as if mark or space

frequencies were selected by a switch, controlled by the keying waveform. However, since sine-wave keying is employed, there will be some overlap when both frequencies are present. The two tone outputs from all channels are added and the aggregate signal applied, as modulation, to a telephone transmitter, almost certainly s.s.b.

At the receiving end, the signal is again demodulated by conventional means, as if it were a telephone channel. The aggregate telegraph signal is then applied to a bank of mark and space selector filters; not only do these filters separate the multi-channel signal into its separate channels but they also separate the mark and space frequencies of each channel.

One major advantage of F.M.V.F. and Two-tone over single tone ON/OFF is that the audio output is of constant amplitude, thus maintaining a continuous level of drive to the transmitter.

### 170 c/s Separation of Tones

Assume a 100 baud signal, i.e. 100 c/s bandwidth per tone. This is obviously the ideal condition which can never be achieved in practice. The minimum separation that can be accepted due to filter design is about 170 c/s.

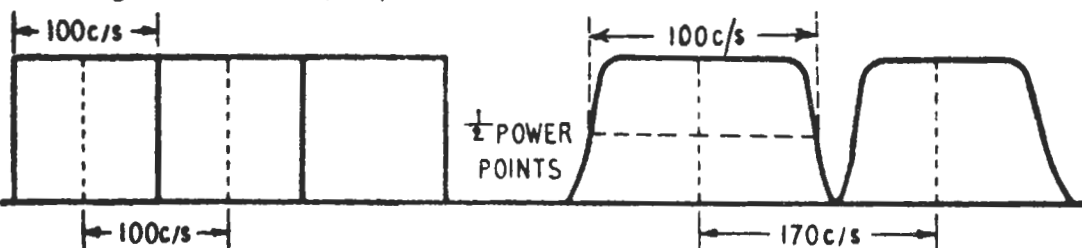

IDEAL FILTER

Diag. 2.12

PRACTICAL FILTER

It can be shown that the ideal separation of the two tones to minimise errors due to multi-path propagation effects is approximately 350 c/s, i.e. twice 170 c/s. Tones are therefore interleaved. The diagram shows the spacing of the tones on the Naval 6-channel V.F.T. circuits.

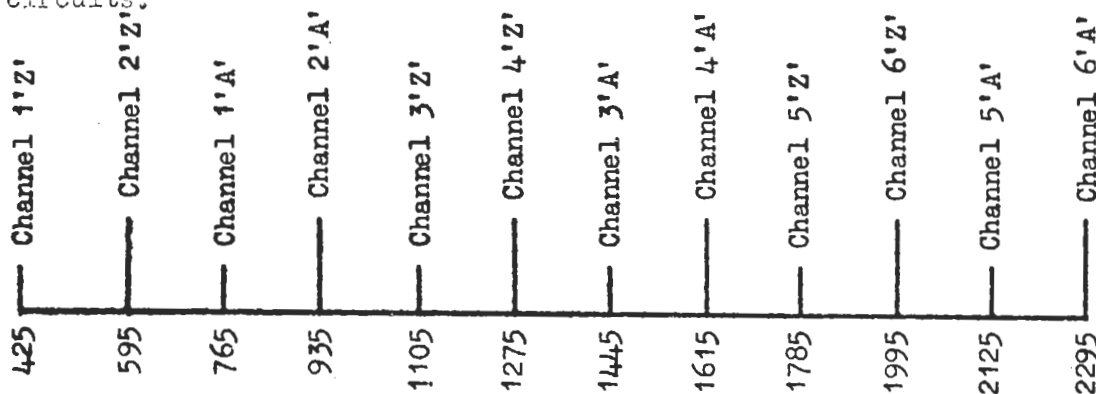

Diag. 2.13

Frequency of Tones c/s

Modern systems will use combinations of 16 tones each spaced 170 c/s apart. These tones will be transmitted on a single side band and will be used for the transmission of digital information between ships. At the same time this modern equipment will be fully compatible with the older equipment still fitted in some ships.

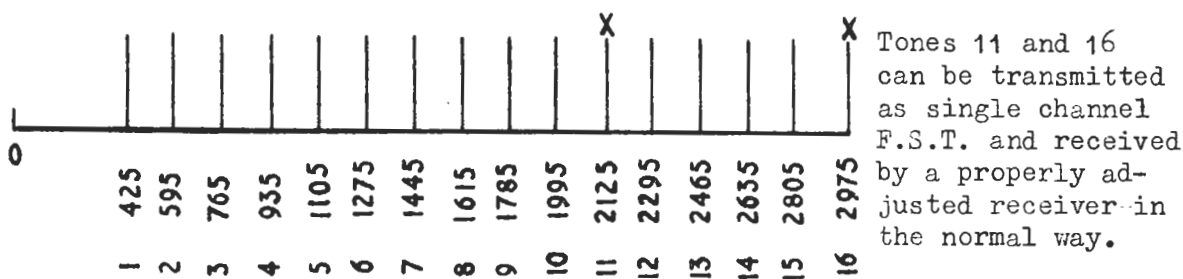

Tones 11 and 16 can be transmitted as single channel F.S.T. and received by a properly adjusted receiver in the normal way.

## Four Frequency Diplex or Double Frequency Shift

A simple method of adapting a single channel f.s.t. system to two channel operation is to employ a four frequency system. The transmitter can be modulated on to one of four discrete frequencies, each frequency representing a unique combination of "Mark" and "Space" on the two channels. Two different coding systems have been used. Code number 2 being used in the Service is shown below.

		Channel 1	Channel 2	
lowest frequency	$f_1$	Z	Z	Teleprinter rest on 'Z' or 'Mark'
	$f_2$	Z	A	
	$f_3$	A	Z	
	$f_4$	A	A	

The frequency separation used in the Service is 400 c/s. This allows keying speeds of between 100 and 200 bauds.

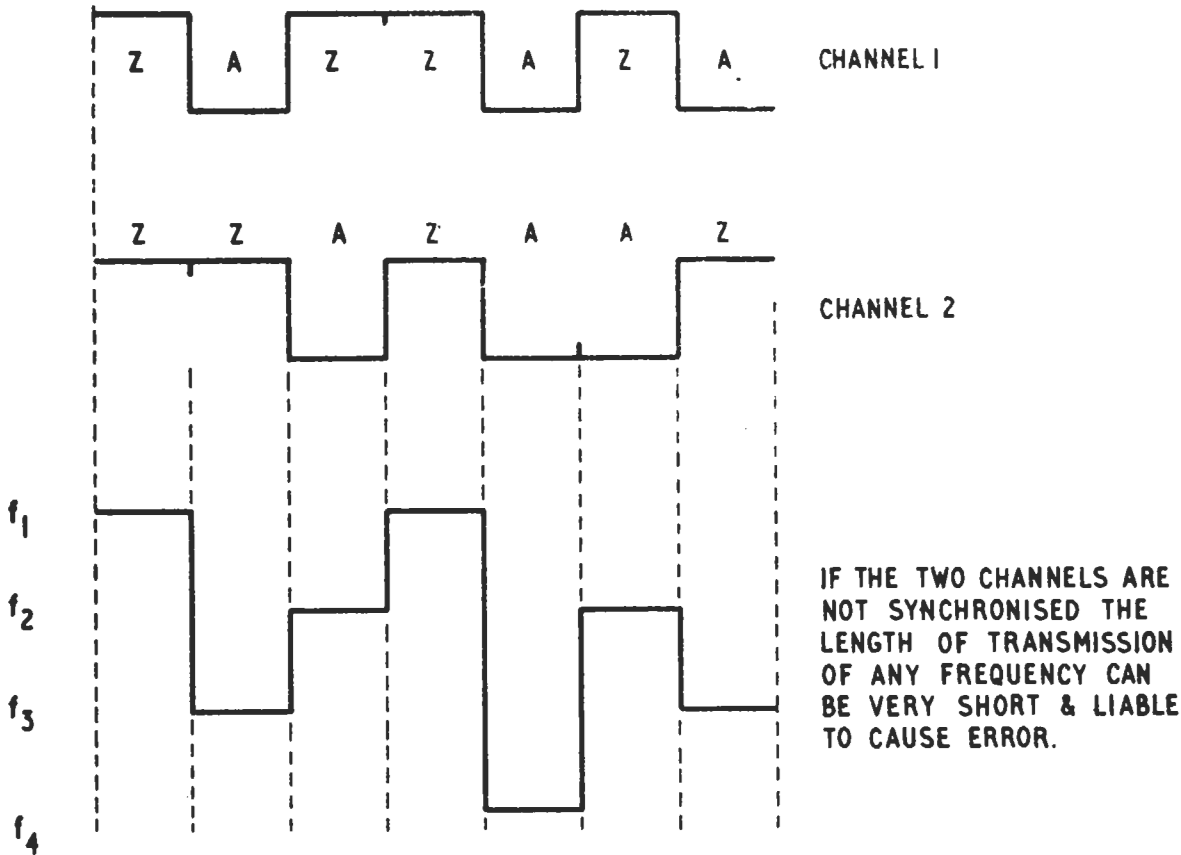

Diag. 2.15

Demodulation can be carried out in two ways. Three discriminators can be used. One differentiates between  $f_1, f_2$  and  $f_3, f_4$ . The other two discriminate between  $f_1$  and  $f_2, f_3$  and  $f_4$ . An alternative method of demodulation is to use a b.f.o. to produce a.f. tones and then to utilise tuned filters.

## Nomenclature of Modulation Methods

All types of modulation can be specified by a letter followed by a numeral.

A, F, or P signifies "Amplitude", "Frequency" or "Phase" Modulation. This is followed by a numeral showing the type of transmission.

0. Continuous Wave
1. Keyed Continuous Wave (c.w.)  
F.I. denotes Frequency Shift Telegraphy
2. Keyed Audio Frequency Modulation  
(i.e. M.C.W. or I.C.W.)
3. Sound modulated waves (i.e. Telephony)
4. Facsimile (i.e. Picture Transmission)
5. Television (Vision only)
6. Four Frequency Diplex
7. Multi Channel Variable Frequency Telegraphy
9. Composite Transmissions

Supplementary characteristics of a Transmission are shown by a letter suffix.

- A. S.S.B. reduced carrier
- H. S.S.B. full carrier
- J. S.S.B. suppressed carrier
- J. S.S.B. Two independent sidebands
- C. Vestigial sideband
- D. Pulse Amplitude Modulation
- E. Pulse width modulation
- F. Phase or position modulation
- G. Pulse code modulation.