

INTRODUCTION

1 With the increase in signal traffic levels to ships and submarines, an increase in the traffic handling capacity of broadcasts has had to be developed.

2 At HF this has taken the form of a multi-channelled broadcast using FDM techniques to form a 4 channel broadcast as shown in Fig 1.

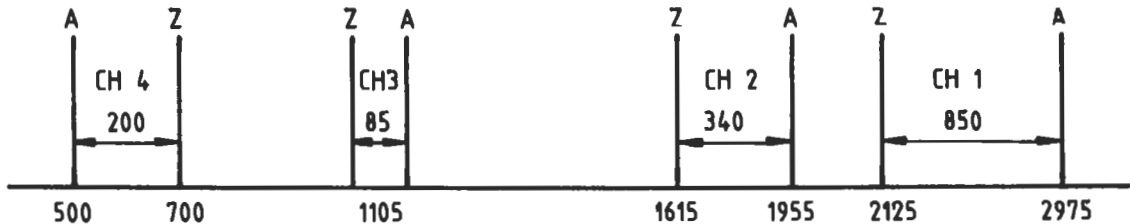

**FIG. 1. INFORMATION BASEBAND 4 CHANNEL
HF MULTI-CHANNEL BROADCAST**

3 This technique is not possible at VLF and LF since these transmitting systems are characterised by narrow RF bandwidths, less than that required for conventional voice ie less than 3 kHz.

4 The assigned bandwidth registered for VLF broadcasts is 200 Hz, but it is the aerial rather than this assigned bandwidth which is the limiting factor, since VLF aeriels are large structures with low efficiency and narrow bandwidths. Typically the half power bandwidth of the VLF aerial is approximately 100 Hz.

5 When FSK at 50 Hz modulation frequency is used at 50 baud to broadcast one channel of information, the power distribution is shown in Fig 2.

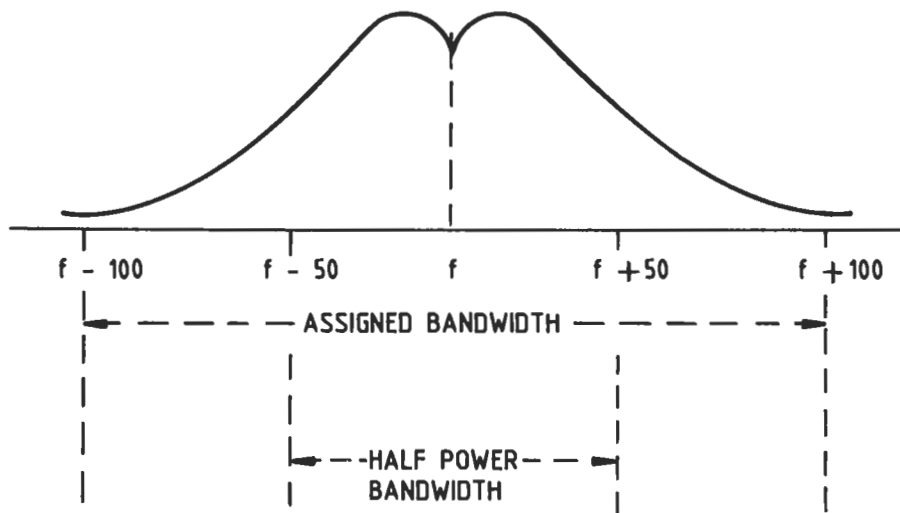

FIG. 2. FSK POWER DISTRIBUTION

6 Any attempt to increase the information flow using FSK requires more power to fall outside the half power bandwidth of the aerial whether a higher baud speed or multi-channelling is used.

7 Use of Minimum Shift Keying (MSK), a form of Quadrature Phase Shift Keying (QPSK) can make optimum use of the narrow bandwidth. The efficiency of the MSK modulation technique can result in a 200 Baud signal occupying only slightly more bandwidth than a 50 Baud FSK signal, thus allowing existing aerials to accommodate the increase in data rate.

8 It is possible to transmit a 100 Baud channel on each pair of phases, and each channel can consist of 2 x 50 Baud TDM channels.

9 Thus MSK can provide a multi-channel broadcast of 2 x 100 Baud or 4 x 50 Baud channels within the assigned bandwidth.

MSK MODULATION

10 Using MSK, 200 Bauds can be transmitted in the form of 4 channels of 50 Baud with a frequency shift of 100 Hz ie a Modulation Index

$$M = \frac{\text{Frequency shift}}{\text{Modulation rate}} = \frac{100}{200} = 0.5$$

achieved with phase continuity.

11 Consider four channels of 50 Baud data TDM (Fig 3). Two sub-channels X and Y are formed by extracting even bits for X and odd bits for Y. The X and Y streams are presented to the modulator.

12 The X and Y streams are passed to two amplitude modulators (Fig 4), also fed by the output of a Weighting Function Generator, phase shifted by 90° in the Y channel. The Weighting Function Generator operates at $\frac{1}{4}$ final Baud speed, ie for a 200 Baud signal $f = 50$ Hz.

13 The outputs of the modulators are respectively:

DX. $\cos wft$ and

DY. $\sin wft$

14 These outputs are fed to two further modulators, fed by the local oscillator output again phase-shifted by 90° in the Y channel. The LO runs at sub-carrier frequency ie 1 kHz.

15 The outputs of these modulators are respectively:

DX. $\cos (wft) \cdot \cos (wot)$ and

DY. $\sin (wft) \cdot \sin (wot)$

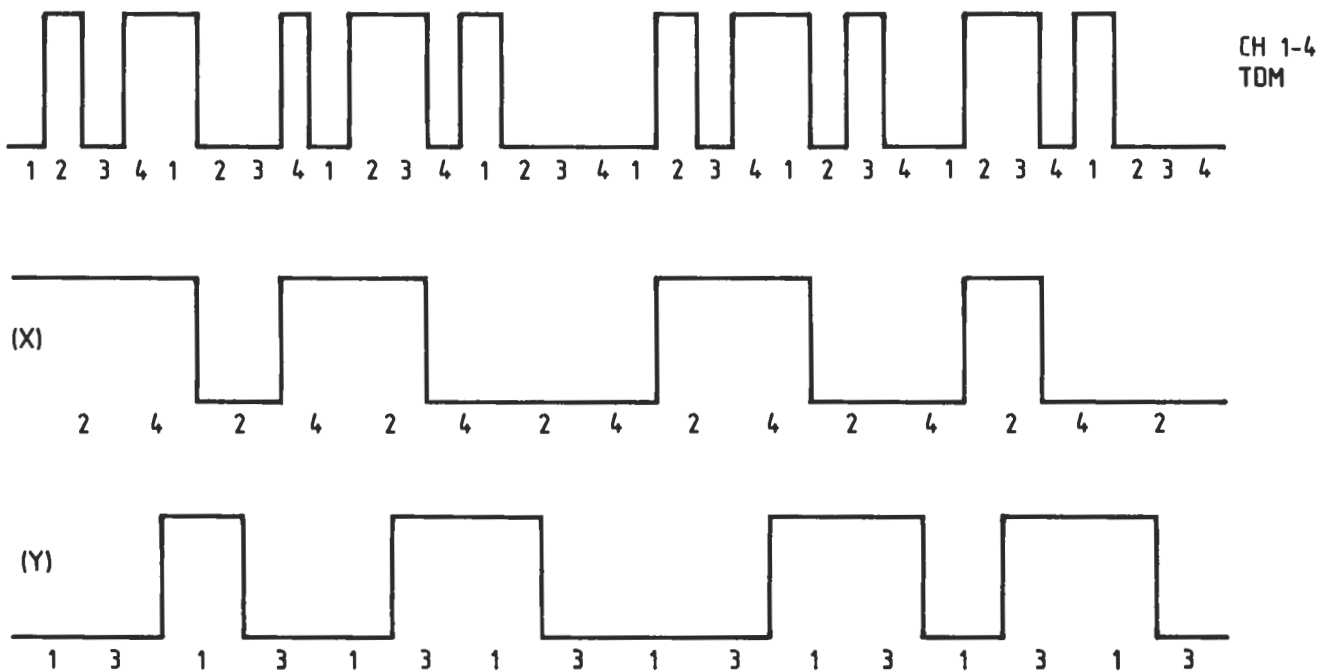
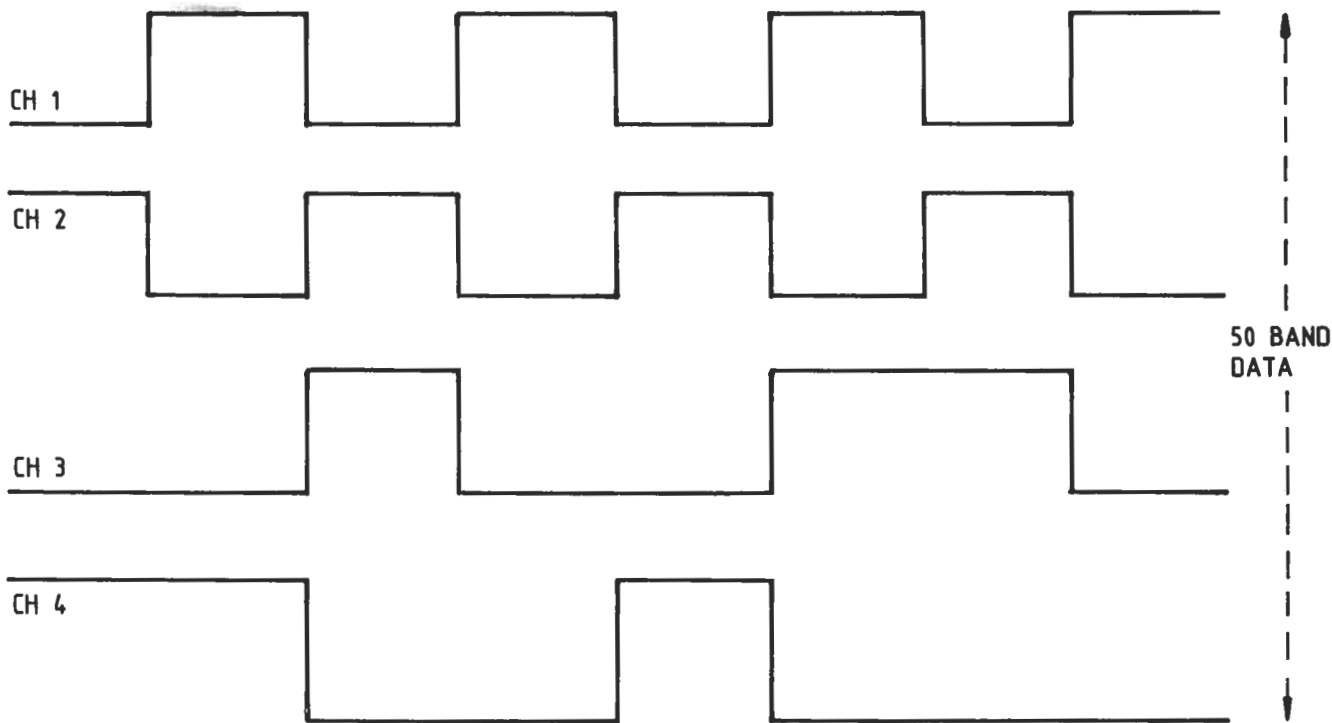

FIG. 3. GENERATION OF AN MSK SIGNAL

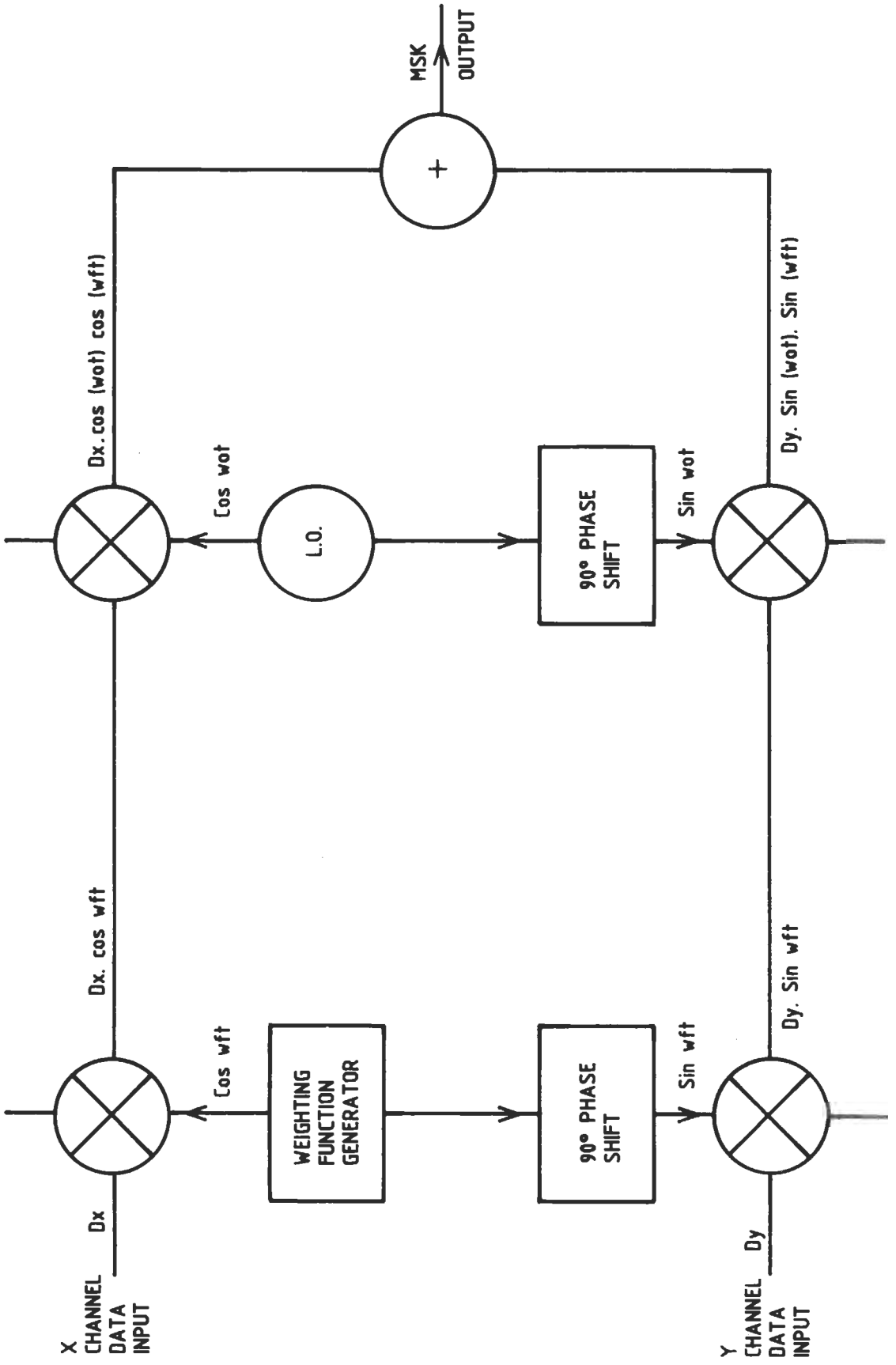

FIG. 4. MSK MODULATOR

16 Since $\cos (a) \cos (b) = \frac{1}{2} [\cos (a + b) + \cos (a - b)]$

and $\sin (a) \sin (b) = \frac{1}{2} [\cos (a - b) - \cos (a + b)]$

and if $(a) = \omega_0 t$ $(b) = \omega_1 t$ then:

$DX \cos (\omega_1 t) \cos (\omega_0 t) = DX/2 [\cos (\omega_0 + \omega_1)t + \cos (\omega_0 - \omega_1)t]$

and $DY \sin (\omega_1 t) \sin (\omega_0 t) = DY/2 [\cos (\omega_0 - \omega_1)t - \cos (\omega_0 + \omega_1)t]$

17 The two modulated output frequencies are then combined (linearly added) to produce a constant amplitude MSK output waveform with instantaneous frequency shifts occurring at times of sub-channel bit transitions.

18 The output from the modulator is:

$DX/2 [\cos (\omega_0 + \omega_1)t + \cos (\omega_0 - \omega_1)t] + DY/2 [\cos (\omega_0 - \omega_1)t - \cos (\omega_0 + \omega_1)t]$

19 If +1 represents one level of digital input and -1 the other level, the MSK modulator output waveform reduces to one of four possible waveforms, as in Table 1.

DATA INPUT		MSK OUTPUT WAVEFORM
DX	DY	
+1	+1	+ $\cos (\omega_0 - \omega_1)t$
-1	-1	- $\cos (\omega_0 - \omega_1)t$
-1	+1	- $\cos (\omega_0 + \omega_1)t$
+1	-1	+ $\cos (\omega_0 + \omega_1)t$

TABLE 1

MSK OUTPUT WAVEFORMS

20 Since the MSK output is determined by the X and Y channel digital data the output waveform will either change or remain the same every data bit period (T seconds).

21 Reference to Table 1 and Fig 5 indicates that certain transitions (eg +1/+1 to -1/-1 and vice versa and +1/-1 to -1/+1 and vice versa) cannot be allowed if phase discontinuity is to be prevented. Allowable transitions are those in which only one sub-channel is allowed to change at the end of a data bit period T. By lengthening the bit period to 2T and inputting the X and Y sub-channels as shown in Fig 6, only one of the sub-channels can change during each time interval T.

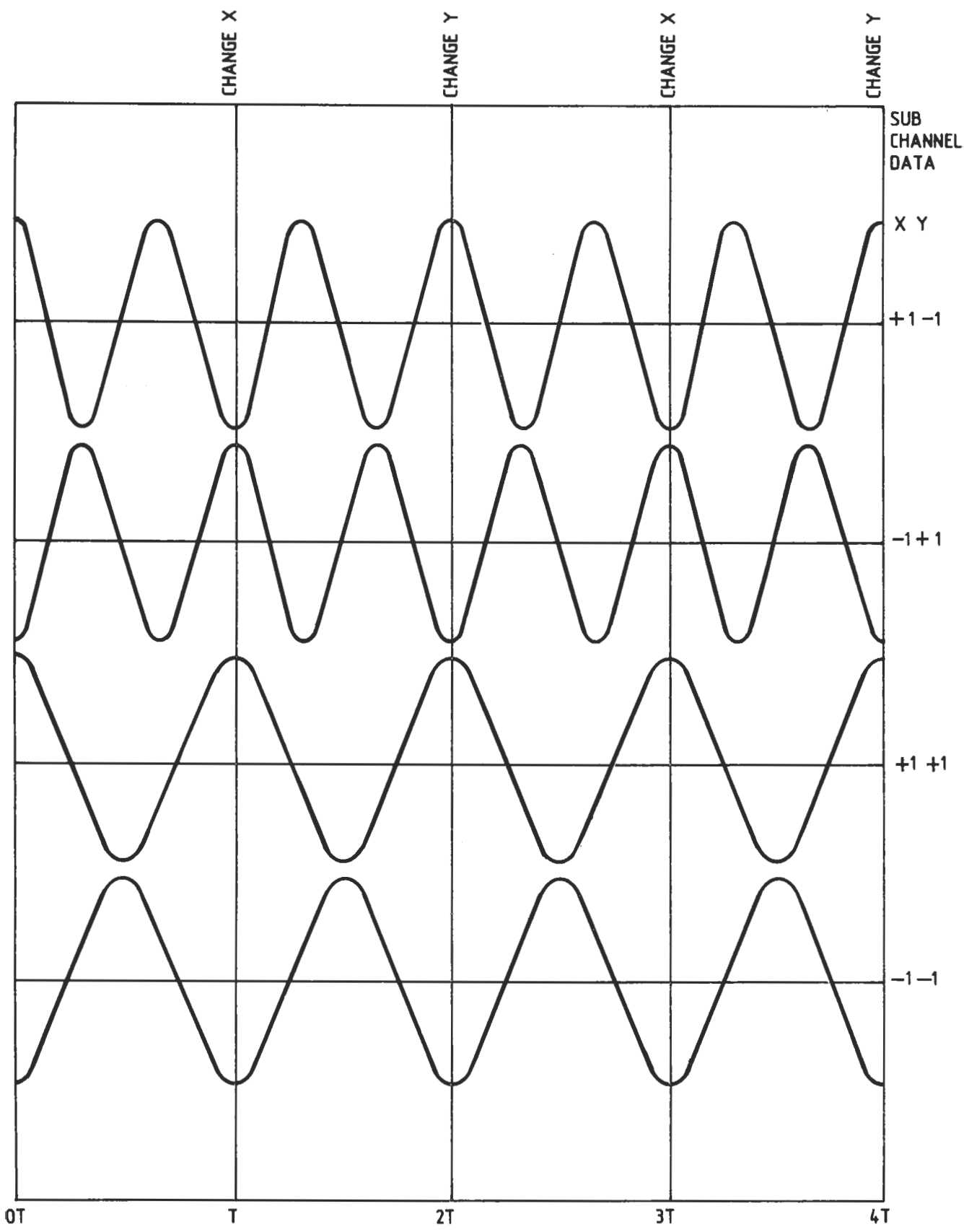

FIG. 5. THE FOUR ALLOWABLE WAVEFORMS FOR MSK MODULATION

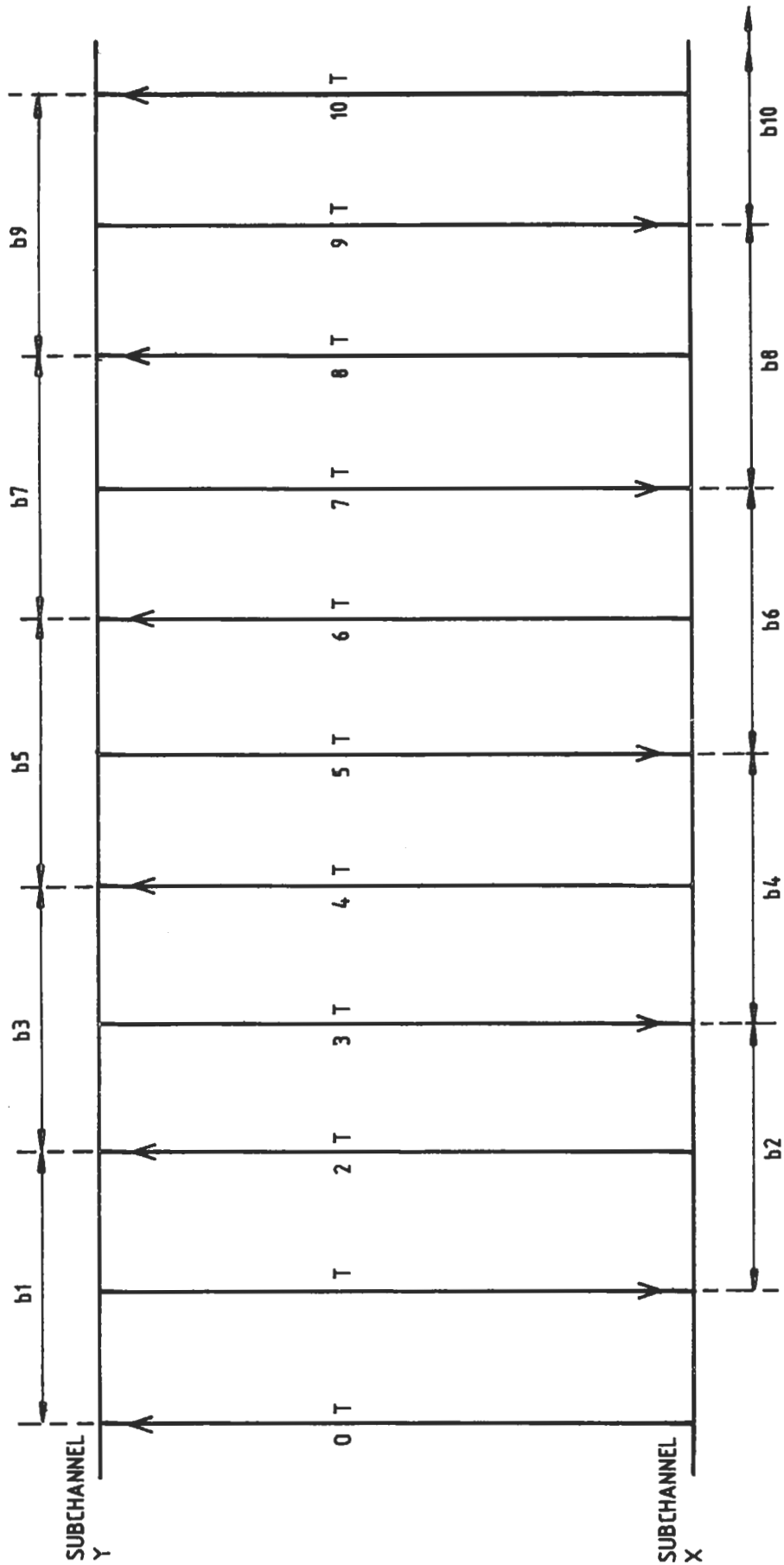
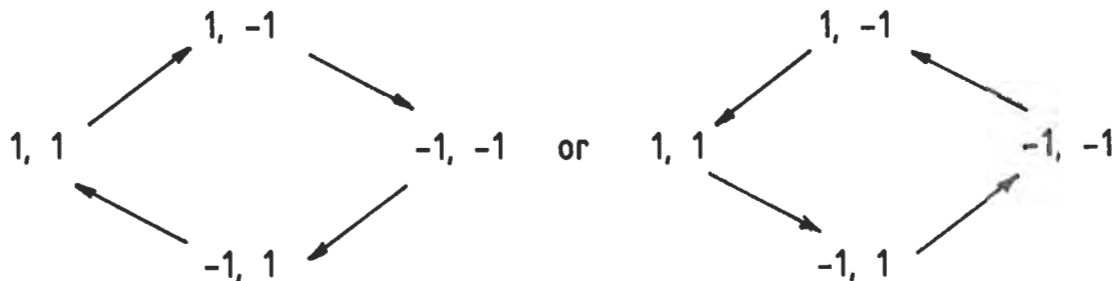

FIG. 6. INPUT DATA TIMING

22 If we change every time interval, the possible situations are:



23 The transmitted signal appears as a phase continuous frequency modulated signal of constant amplitude. The frequency shift is $\pm \frac{1}{4}$ of the modulation rate and occurs at the modulation rate.

24 Because of its sinusoidal rather than rectangular pulse shape, MSK requires a much smaller bandwidth than FSK at the same modulation rate.

25 In practice the required bandwidth is only a small increase on that required for FSK transmission at 50 Baud.

PRINCIPLES OF MSK RECEPTION (Fig 7)

26 The received audio is one of two frequencies $(\omega_0 + \omega_f)t$ and $(\omega_0 - \omega_f)t$, each of which may be in one of two phase states (Table 1).

27 The audio signal is separated into two frequency channels, each of which must be passed to a phase discriminator giving one of four possible outputs representing X, Y signal combinations of 1,1; -1, -1; 1, -1; -1,1.

28 These signals, clocked at 200 Baud are split into X and Y aggregate channels each at 100 Baud. Using TDM principles these are then split to give four 50 Baud traffic channels for distribution to users.

Synchronisation of Channels

29 Submarine broadcast encryption is about to change from the present single channel system using start-stop bits for character identification to a multi-channel system which requires not only character framing, but must also permit channel identification at the receiver.

30 To achieve this a Fibonacci series of unencrypted bits is included in alternate characters of Vallor traffic channels, with the 1s and 0s of this sequence being inverted in Channel 1 to permit identification of this channel, thus automatically identifying channels 2 to 4.

Empty Channel Filler (ECF)

31 The MSK transmission system requires four traffic channels for successful operation. In conditions where no messages are available for transmission, empty channel filler data is generated automatically at the transmitter drive equipment.

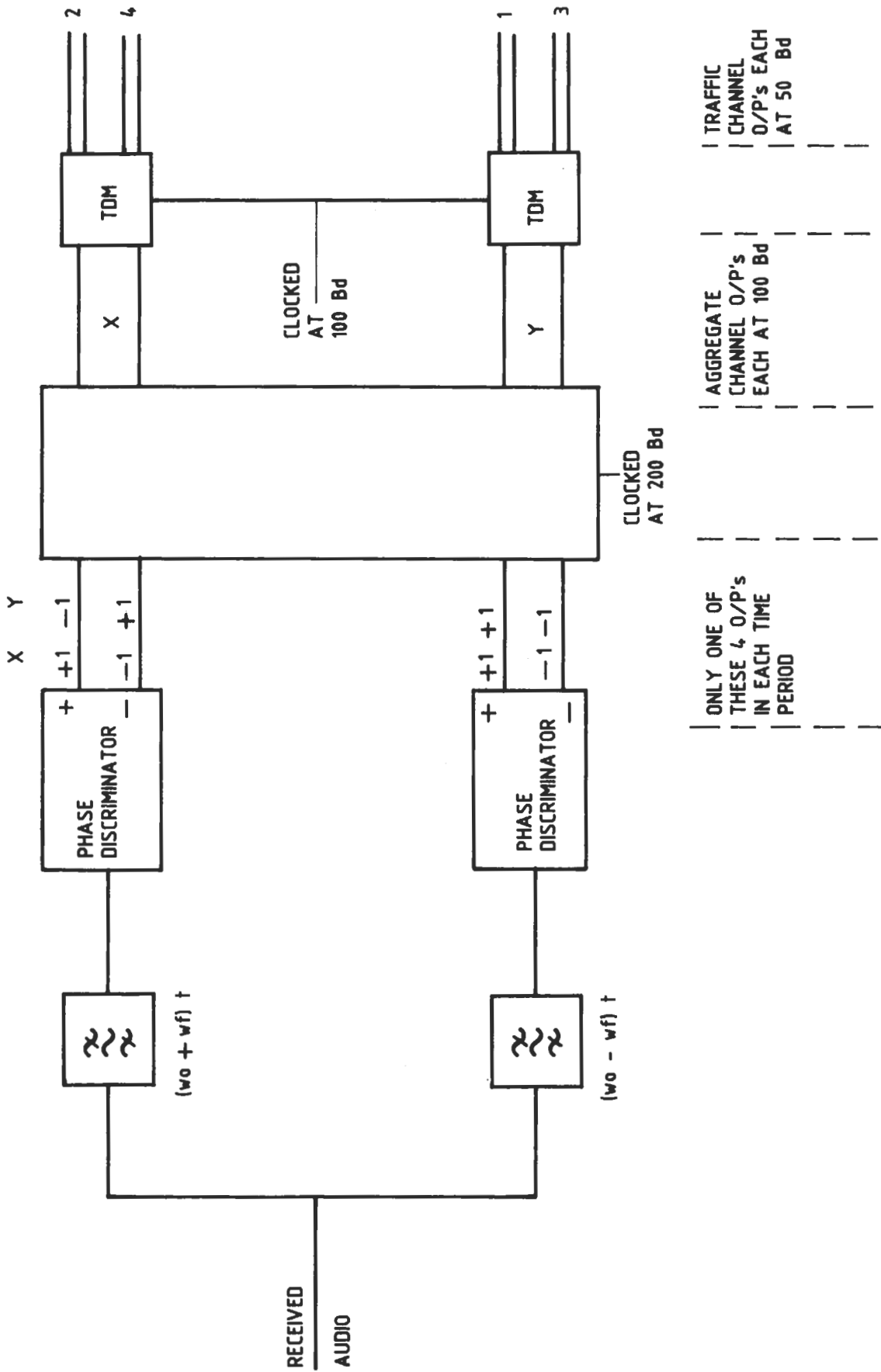

FIG. 7. PRINCIPLES OF MSK RECEPTION

32 For channels 2, 3 and 4, this information will be a constant RY2 RY2 RY2 (or RY3, RY4) pattern unencrypted.

33 For channel 1, a specific filler pattern will be used.

Error Detection and Correction (EDAC)

34 The MSK system allows the facility of Error Detection and Correction to be applied. This allows the correction of one corrupted received bit in 14, resulting from atmosphere/propagation effects.

35 The EDAC process uses Wagner coding. At the transmitter the 14th bit of two characters becomes a Wagner bit, and will be a 1 or 0 such that the total bits in the two characters, ignoring the Fibonacci bit in alternate characters, but including the Wagner bit, is of odd parity.

36 At the receiver, with EDAC selected, the Wagner bits are decoded and a parity check carried out.