

D/F OUTFIT FC,
ARRANGEMENT OF PANELS.

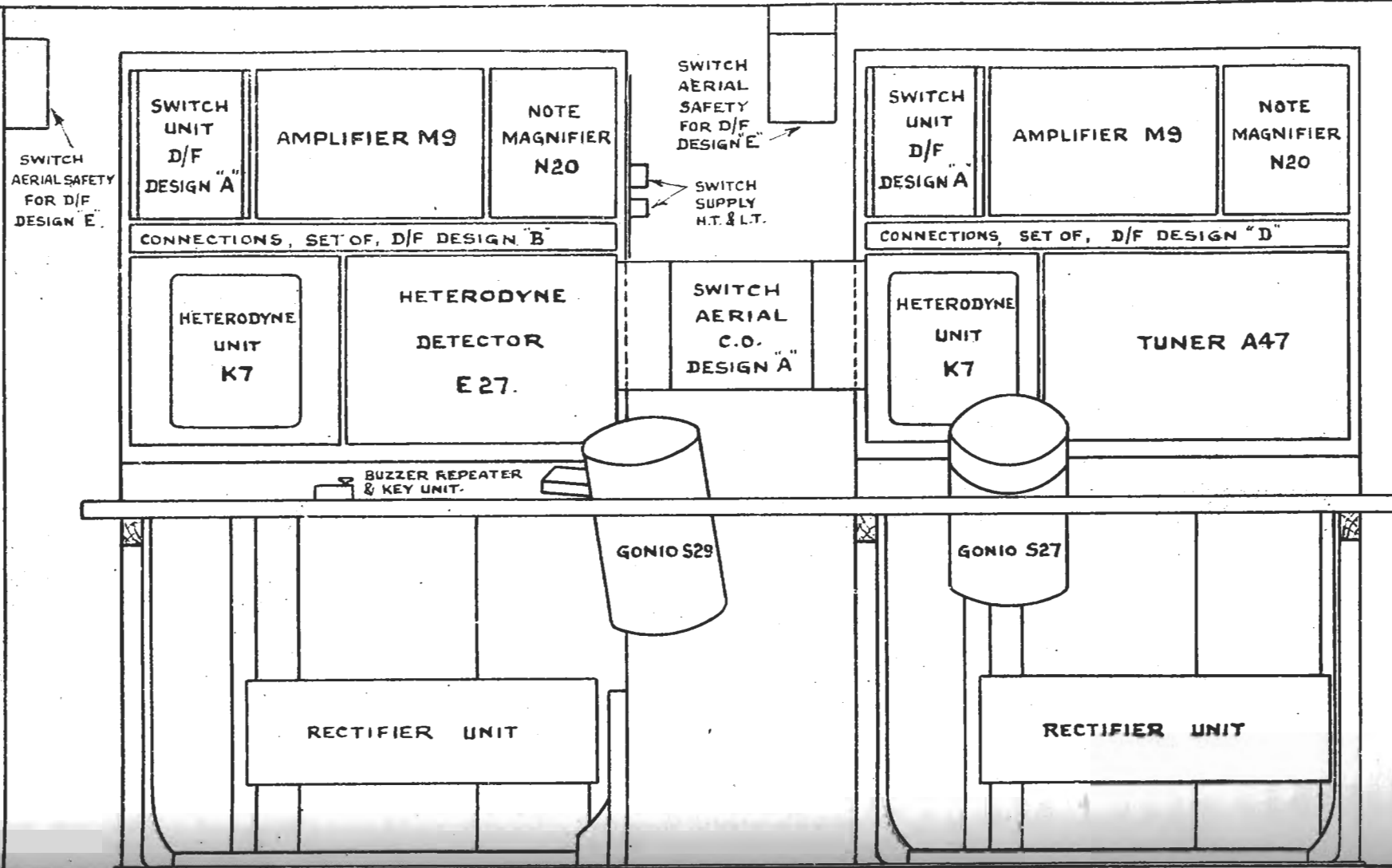

CHAPTER V.

D/F OUTFIT FC.

1. GENERAL DESCRIPTION. D/F outfit FC is used for simultaneous reception on M/F and H/F with arrangements for taking D/F bearings on M/F or H/F alternatively.

The M/F frequency range is 60 to 600 kc/s. and the H/F range 667 to 20,000 kc/s.

The outfit has been designed for use by two operators with separate open aeriads and receiving outfits for the M/F and H/F ranges. Simultaneous reception is carried out on M/F and H/F by using the two open aeriads, but D/F bearings, using the frame coil, can only be taken on M/F and H/F alternatively.

The M/F open aerial is also used for obtaining "Sense" when the frame coil is used for direction finding on M/F.

All the components used in outfit FC which are common to outfits FA, FC and FH are described in Chapters I, II and III.

2. RECEIVING INSTRUMENTS. All the M/F receiving instruments are grouped in one panel and the H/F instruments in another as shown in Fig. 25, the aerial change-over switch being fitted between them in a convenient position for use by either the M/F or H/F operator.

Both goniometers are supported on a table in front of the D/F panels, in positions convenient for the operators' use.

A diagram of the connections for both the M/F and H/F receiving apparatus is shown in Fig. 26 and the H.T. and L.T. supplies to the valves in Fig. 27.

3. M/F APPARATUS.

Radio-goniometer	S27.
Tuner	A47.
Amplifier	M9.
Note Magnifier	N20.
Heterodyne unit	K7.

When the aerial change-over switch is set to M/F, the loops of the frame coil are connected to the field windings of the goniometer S27, the search coil of which is connected to the input circuit of the tuner A47. The output terminals of tuner A47 are connected to the "Receiver" switch on the switch unit and thence to the input terminals of amplifier M9.

Signals are amplified and detected in the M9 and then passed to note magnifier N20 and thence to the telephones.

For the reception of C.W. signals, a heterodyne unit K7 is used as a separate heterodyne and is connected to the heterodyne terminals of amplifier M9.

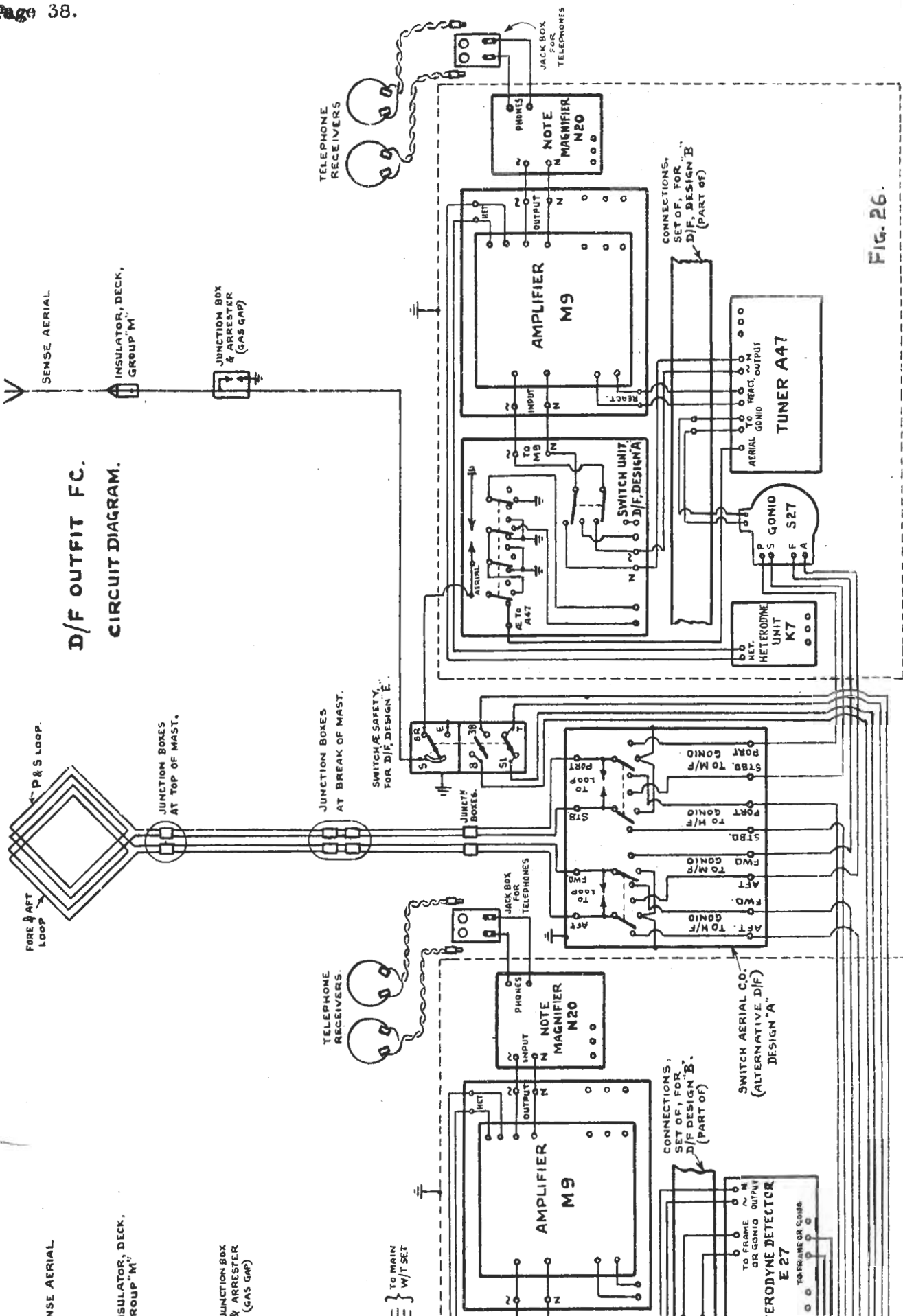
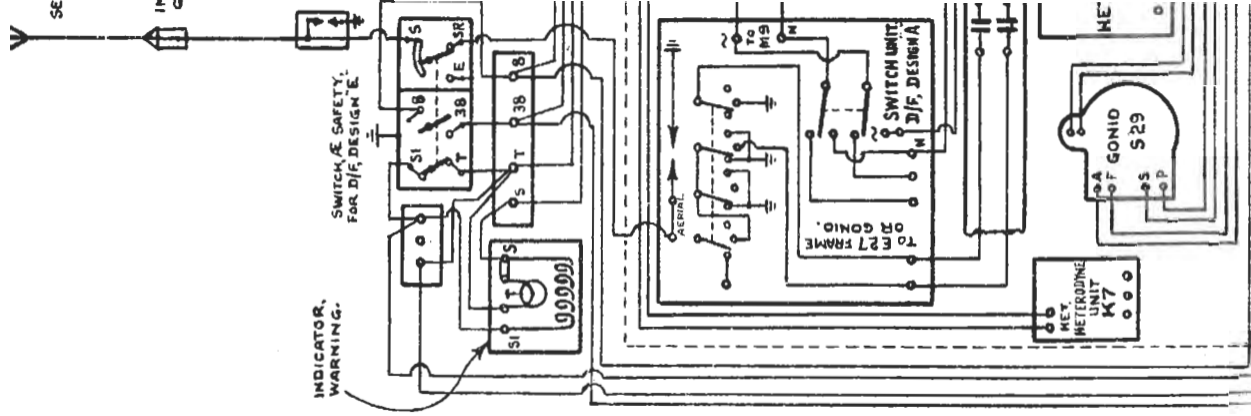

Fig. 26.



RACK, UPPER

D/F OUTFIT F.C.
SUPPLY TO VALVES

RACK, UPPER

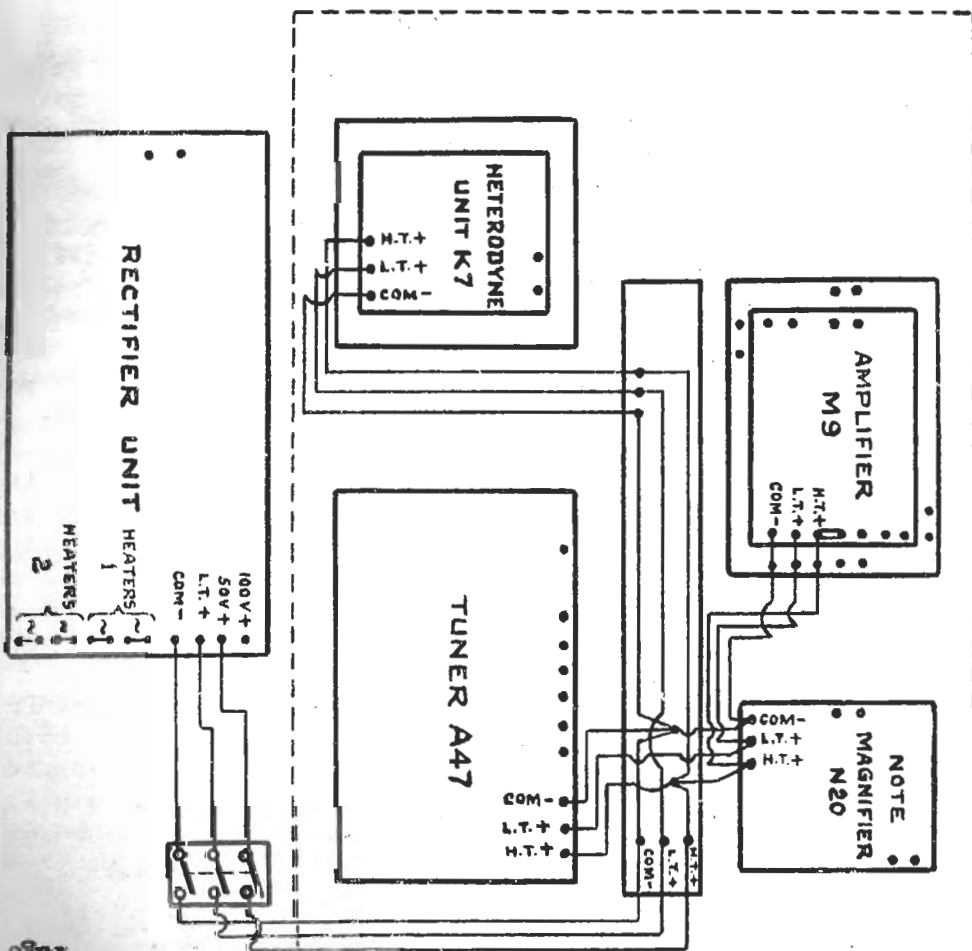
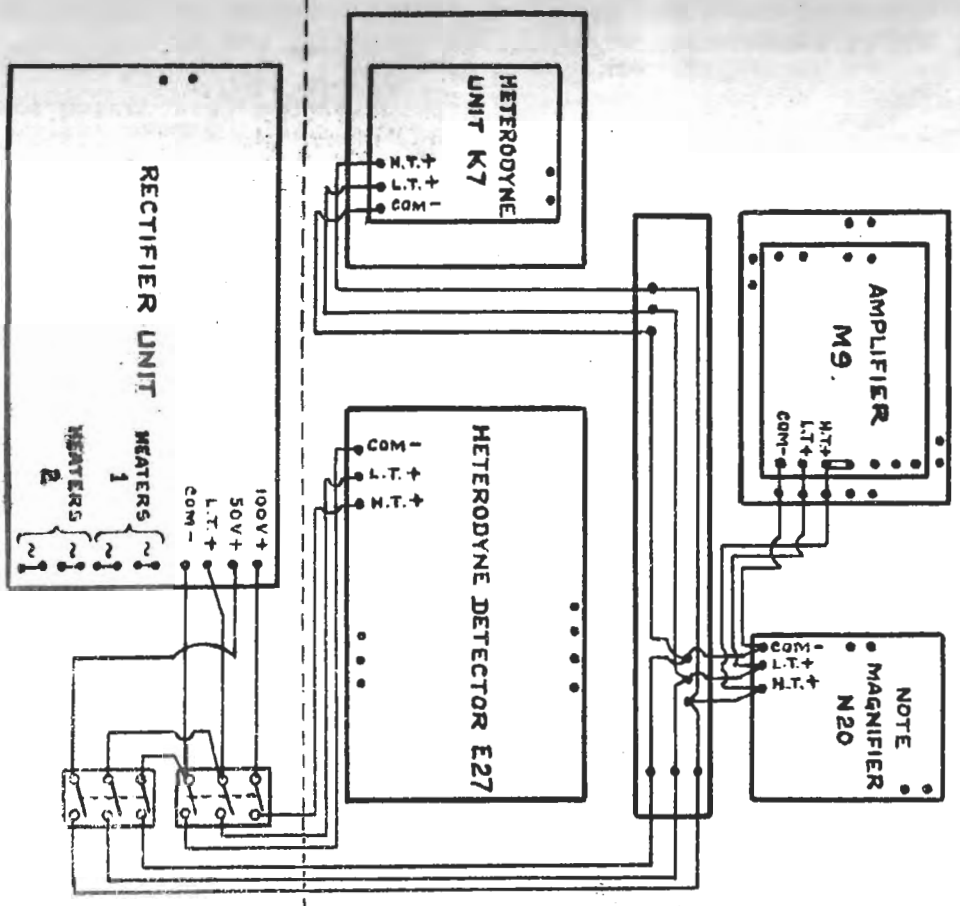

Fig. 27

4. OPERATION (M/F). In order to take a D/F bearing on any frequency in the range covered by the M/F apparatus, the tuner A47 and, for C.W. reception, the heterodyne unit K7, must be set to the correct adjustments. The tuner A47 can be tuned by means of the K7 which has engraved discs fixed to the tuning condenser handle for rough adjustments and a book of calibration curves for accurate settings.

When searching for signals on M/F, the M/F open aerial is used by setting the switch unit to "M/F" and the aerial switch on tuner A47 to the "Sense" position. If not already in use by the H/F operator the frame coil can be used in conjunction with the M/F open aerial to obtain a greater signal strength while "searching". It should be noted, however, that, as the frame coil is used for both M/F and H/F, great care must be taken to avoid confusion by altering the settings of the aerial change-over switches when the frame coil is in use for the purpose of taking a D/F bearing.

When a signal is heard on M/F of which it is desired to take a D/F bearing, the aerial switch on tuner A47 must be set to "D/F" and the aerial change-over switch set to "M/F" but it is not necessary to alter the setting of the switch unit.

It is important to note that, when the switch unit is left in the M/F position, the M/F open aerial is controlled by the aerial switch on tuner A47 and this switch must be always set to "D/F" when taking a D/F bearing.

D/F bearings are taken in the usual manner, corrections being made automatically by means of the cam correctors which are fitted to the goniometers after calibration.

The method of using the sensefinder to obtain "Sense" is as follows :-

When a bearing, or its reciprocal, has been obtained with the aerial switch on Tuner A47 in the "D/F" position, the goniometer search coil is brought to rest in one of the minimum signal strength positions. The A47 aerial switch is then moved to "Sense" when louder signals will be obtained. The aerial series condenser is then adjusted to give approximately the same signal strength as would be obtained with the goniometer search coil in the position of maximum signal strength.

If the signals DECREASE in strength when the goniometer is rotated in a CLOCKWISE direction the MINIMUM on which the pointer rested indicates the true bearing of the station.

The instructions for cutting the cam blanks are given in Chapter VIII.

5. H/F APPARATUS.

Radio-goniometer	S29.
Heterodyne detector	E27.
Amplifier	M9
Note magnifier	N20
Heterodyne unit	K7

When the aerial change-over switch is set to H/F, the loops of the frame coil are connected to the field windings of the goniometer S29, the search coil of which is connected to the input circuit of the heterodyne detector E27 in which the incoming signals are heterodyned and detected.

The output terminals of the E27 are connected to the "Receiver" switch on the switch unit and thence to the input terminals of amplifier M9, which is used as an intermediate amplifier working on a frequency of approximately 100 kc/s. Rectified signals from the M9 are passed to the note magnifier N20 and thence to the telephones.

For the reception of C.W. signals a heterodyne unit K7 is used as a separate heterodyne and is connected to the heterodyne terminals of amplifier M9.

Two 0.03 jar condensers are fitted in a box attached to the strap carrying the connecting leads on the front of the panels. These condensers are connected in the open aerial connecting leads between the switch unit and the heterodyne detector E27 in order to reduce the effective capacity of the leads, which otherwise would be thrown across the search coil of the goniometer.

6. OPERATION (H/F). In order to take a D/F bearing on any frequency in the range covered by the H/F apparatus the appropriate coils must be plugged into the heterodyne detector E27. The heterodyne and detector circuits of this instrument are then tuned to the required frequency by using the engravings on the discs of the tuning condensers or by reference to the curves of settings supplied with the outfit. The heterodyne unit K7 should be switched on and tuned to the frequency of the intermediate amplifier, i.e., 100 kc/s. (the range switch of the K7 will be set at position 2 and the tuning condenser at 30° approximately).

The sensitivity of the E27 should be controlled by means of the reaction condenser, the sensitivity increasing with the condenser setting. The value of reaction should not be increased to the point where the detector circuit oscillates; it should not exceed about $10^{\circ} - 20^{\circ}$.

The heterodyne detector should be slowly adjusted by means of the slow motion control until the required signals are heard and the detector circuit retuned, if necessary, until signals are loudest.

If I.C.W. signals are being received it may be advantageous to switch off the K7 after tuning E27 but, for tuning purposes, the characteristic rustle produced by the K7 when the heterodyne and detector circuits are in tune together, will always be found an aid.

If it is necessary to search over an appreciable band of frequencies for any station the heterodyne and detector condensers should be adjusted together.

When searching for signals on H/F, the H/F open aerial is used by setting the "open aerial" switch on the switch unit to the "H/F Search" position.

If not already in use by the M/F operator, the frame coil can be used in conjunction with the H/F open aerial to obtain a greater signal strength while searching. It should be noted, however, that, as the frame coil is used for both M/F and H/F, great care must be taken to avoid confusion by altering the settings of the aerial change over switches when the frame coil is in use for the purpose of taking a D/F bearing.

When a signal is heard of which it is desired to take a D/F bearing, the H/F open aerial must be isolated by the switch unit before bearings are taken. This is done by setting the open aerial switch to "H/F".

The relative bearings are taken in the usual way by observing the position of minimum signal strength and checking the observation on the reciprocal minimum. Operators should guard against recording false minima due to fading and, when fading occurs, observations should be made when signals are loudest.

Any variation in position of bearings and in the definition of the minima should be noted and reported.

Page 42.

Relative D/F bearings should be corrected in accordance with the curves supplied after calibration, and converted to true bearings by reference to the gyro scale on the goniometer. It should be noted that the corrections required for any observed bearing and its reciprocal are not necessarily equal. Accordingly, since no provision is made in this outfit for determining "sense" on H/F, the D/F operator should always report two corrected bearings, which, in general, will not differ by 180 degrees. In such circumstances other information may be available for deciding which of these two bearings is the correct one.