

- V52 - Characteristics of distortion and error rate measuring apparatus for data transmission.
- V53 - Limits for the maintenance of telephone-type circuits used for data transmission.
- V54 - Loop test devices for modems.
- V55 - Specification for an impulsive noise measuring instrument for telephone-type circuits.
- V56 - Comparative tests for modems for use over telephone-type circuits.
- V57 - Comprehensive data test set for high data signalling rates.

#### X Series recommendations covering data networks

- X1 - International user classes of service in public data networks.
- X2 - International user facilities in public data networks.
- X3 - Packet assembly/disassembly facility (PAD) in a public data network.
- X4 - General structure of signals of International Alphabet No 5 code for data transmission over public data networks.
- X20 - Interface between data terminal equipment and data circuit-terminating equipment for start/stop transmission services on public data networks.
- X20 bis - V21 - compatible interface between data terminal equipment and data circuit-terminating equipment for start-stop transmission services on public data networks.
- X21 - General purpose interface between data terminal equipment and data circuit-terminating equipment for synchronous operation on public data networks.
- X21 bis - Use on public data networks of data terminal equipments which are designed for interfacing to synchronous V-series modems.
- X24 - List of definitions of interchange circuits between data terminal equipment and data circuit-terminating equipment on public data networks.
- X25 - Interface between data terminal equipment and data circuit-terminating equipment for terminals operating in the packet mode on public data networks by dedicated circuit.

- X26 - Electrical characteristics for unbalanced double-current interchange circuits for general use with integrated circuit equipment in the field of data communications (identical to V10).
- X27 - Electrical characteristics for balanced double-current interchange circuits for general use with integrated circuit equipment in the field of data communications (identical to V11).
- X28 - DTE/DCE interface for start/stop mode data terminal equipment accessing the packet assembly/disassembly facility (PAD) on a public data network situated in the same country.
- X29 - Procedures for exchange of control information and user data between a packet mode DTE and a packet assembly/disassembly facility (PAD).
- X30 - Bit Rate adaption in support of X21/X21 bis based DTEs by an ISDN.
- X32 - Support of Packet mode Terminal by an ISDN.
- X32 - Interface between DTE and DCE for terminals operating in Packet mode and accessing a PSS network through the PSTN or circuit switched Public data Network.
- X50 - Procedures for muxing-demuxing 64 K bits WAL2.
- X92 - Hypothetical reference connections for public synchronous data networks.
- X95 - Network parameters in public data networks.
- X96 - Call progress signals in public data networks.
- X75 - Procedures for transferring data between different PDNs national and international.
- X121 - International numbering plan for PDNs.
- X400 - Message handling system model service elements.
- X401 - Message handling basic systems service elements and optional user facilities. X401 is a definition of the service elements of both the inter-personal messaging service and the message transfer service.
- X408 - Message handling encoded systems information type conversion rules.
- X409 - Message handling presentation systems transfer syntax and notation.
- X410 - Message handling remote systems operations and reliable transfer server.

- X411 - Message handling message systems transfer layer.
- X420 - Message handling inter-personal systems messaging user agent layer.
- X430 - Message handling access systems protocol for telex terminals.

## G Series Recommendations

- G703 - Interface for raw delivery of 2.048 M bits using HDB3 line coding.
- G711 - Speech encoding conforming to A-Law characteristics (64 K).
- G712 - Performance governing speech encoding to A-Law characteristics (64 K).
- G732 - Interface for 2.048 M bits with 32 time slots.
- G737 - Access method for muxes using 64 K bits time slots.
- G821 - Performance parameters for digital services between 64 K and 2.048 M bits/sec.

## I Series Recommendations for ISDNs

- 1110 - General structure of 'I' Series recommendations with other recommendations.
- 1111 - Relevant to ISDNs.
- 1112 - Vocabulary of terms for ISDN.
- 11120 - Integrated service digital networks.
- 11130 - Attributes for the characterisation of Telecoms services supported by an ISDN and network capabilities of an ISDN.

## Part 2 (Service Capabilities)

- 1210 - Principles of Telecoms services supported.
- 1211 - Bearer services supported by an ISDN.
- 1212 - Teleservices supported by an ISDN.

Telecoms services = Bearer Services + Teleservices.

### Part 3 Overall Network Aspects and Functions

- 1310 - ISDN network functions and principles.
- 1320 - ISDN protocol reference model.
- 1330 - ISDN numbering and addressing principles.
- 1331 - Numbering plan for ISDN era.
- 1340 - ISDN connection types.

### Part 4 (User Network Interfaces)

- 1410 - General aspects and principles relating to recommendations on ISDN user network interfaces.
- 1411 - ISDN user network interfaces - reference configuration.
- 1412 - ISDN user network interfaces - channel structures and access capabilities.
- 1420 - Basic user network interface.
- 1421 - Primary rate user network interface.
- 1430 - Basic user network interfaces - Layer 1 specification.
- 1431 - Primary rate user network - Layer 1 specification.
- 1440 - ISDN user network interface data link layer - general aspects.
- 1441 - ISDN user network interface data link layer - specifications.
- 1450 - ISDN user network interface Layer 3 - general aspects.
- 1451 - ISDN user network interface Layer 3 specifications.
- 1461 - Support of X21 and X21 bis DTEs by an ISDN.
- 1462 - Support of packet mode terminal equipment by an ISDN.
- 1463 - Support of V Series type interfaces by an ISDN.
- 1464 - Rate adaption multiplexing and support of existing interfaces for restricted 64 K/bits transfer capability.

THE INTERNATIONAL STANDARDS ORGANISATION -  
OPEN SYSTEMS INTERCONNECTION REFERENCE MODEL

INTRODUCTION

1. In 1977, the International Organisation of Standardisation (ISO) recognised the special and urgent need for standards for the various types of information networks and created a subcommittee for 'Open Systems Interconnection'.
2. The initial development of computer networks had been led by experimental networks immediately followed by computer manufacturers. Each manufacturer devised his own set of conventions for interconnecting his own equipment, referring to these as his 'network architecture'.
3. The universal need for interconnecting systems from different manufacturers became apparent, leading ISO to decide on the creation of standards required for Open Systems Interconnection.
4. The term 'Open' was chosen to emphasise the fact that by conforming to those international standards, a system would be open to all other systems obeying the same standards throughout the world.
5. Initial discussion revealed that a LAYERED ARCHITECTURE which would satisfy most requirements of OSI with the capacity of being expanded later to meet new requirements, could be rapidly agreed.
6. It was decided to give priority to development of a standard model of architecture which would constitute protocols. This task was completed by the end of 1979 and recommendations for development of such protocols were adopted as the basis for development of standards for Open System Interconnection.
7. By standardisation of the rules of interaction between interconnected systems, only the external behaviour of open systems must conform to OSI Architecture, while the internal organisation and functioning of each individual open system is outwith the scope of OSI standards since these are not visible from other systems with which it is interconnected.

Principles of Layering

8. The technique of layering in communications is used to reduce the design complexity of networks. The function of each layer is to offer services to the higher layers, while shielding those higher layers from the details of how the services offered are actually implemented.

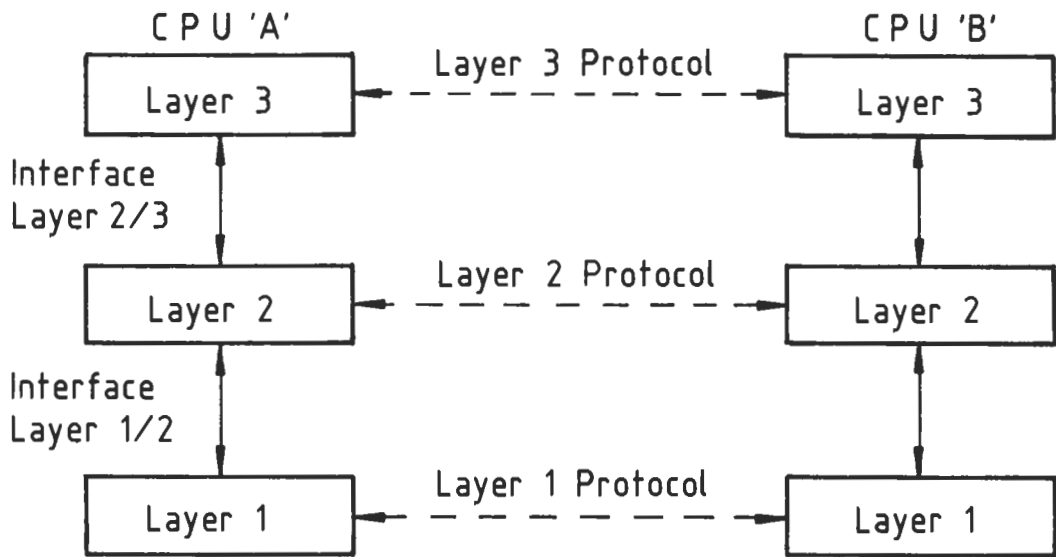

FIG 9B.1 PRINCIPLES OF LAYERED PROTOCOLS

9. Layer protocol collectively describes the rules and procedures that govern the communication between corresponding layers. In a layered system, communication can only exist between corresponding layers i.e layer 3 to layer 3, layer 2 to layer 2 etc. Fig 9B.1 shows part of the OSI model illustrating the principles of layered protocols.

10. The layered protocols are conceptual links with the exception of the lowest layer protocol which controls the physical communication path.

11. Layer Interfaces - data is not transferred directly to and from corresponding layers, but passed up and down through the layers. The layer interface provides the translation between layers.

### The OSI Model

12. The OSI model consists of 7 layers, as illustrated in Fig 9B.2 which shows the layer names and the format of information as it is passed between layers. The dotted lines represent the conceptual or virtual protocol links between layers while solid lines represent physical communication paths.



- (1) Encryption.
- (2) Code conversion.
- (3) Compression.
- (4) Display formatting.

16. The presentation layer provides services through which the application can communicate with acceptable costs in interface variability or application modification.

17. Layer 5 - The Session Layer. This layer provides services which can be split into 2 categories:

- (1) Session administrative service. Binds two presentation entities into a relationship eg by authenticating each party before they can engage in the session.
- (2) Session dialogue service. Controls data exchange, synchronising data operations between two presentation entities.

18. Layer 4 - The Transport Layer. This layer provides a universal transport service end-to-end in association with lower layers. The layer provides transparent transfer of data between session entities, relieving them from any concern with the detailed way in which reliable and cost effective data transfer is achieved over the network.

19. The Transport Layer is required to optimise the use of available communication services to provide a connection between session entities at a minimum cost. It isolates the session layer from the inevitable changes in hardware technology.

20. Layer 3 - the Network Layer. This layer provides functional and procedural means of exchanging information between two transport entities over a network connection. It provides routing and switching information for use by network information processors eg Level 3 of CCITT Recommendation X25.

21. Layer 2 - The Data Link Layer. This layer provides the functional and procedural means to control error free data links between network entities eg host to network information processors.

22. Layer 1 - The Physical Layer. This layer provides mechanical, electrical, functional and procedural characteristics to control physical connections between data link entities eg CCITT V24, X21 and EIA RS232.

BRITISH TELECOM DIGITAL SERVICES

Introduction

1. With UK, British Telecom (BT) is the primary supplier of telecommunication transport services. Accordingly the NSTN utilises such services including some BT Digital Services.

2. The range of BT Digital Services are known as the X-Stream Services, since 'X' is an internationally recognised symbol signifying digital operation. The X Stream Services are known as Switch Stream, Video Stream, Megastream, Kilostream and Sat Stream (Fig 9C.1).

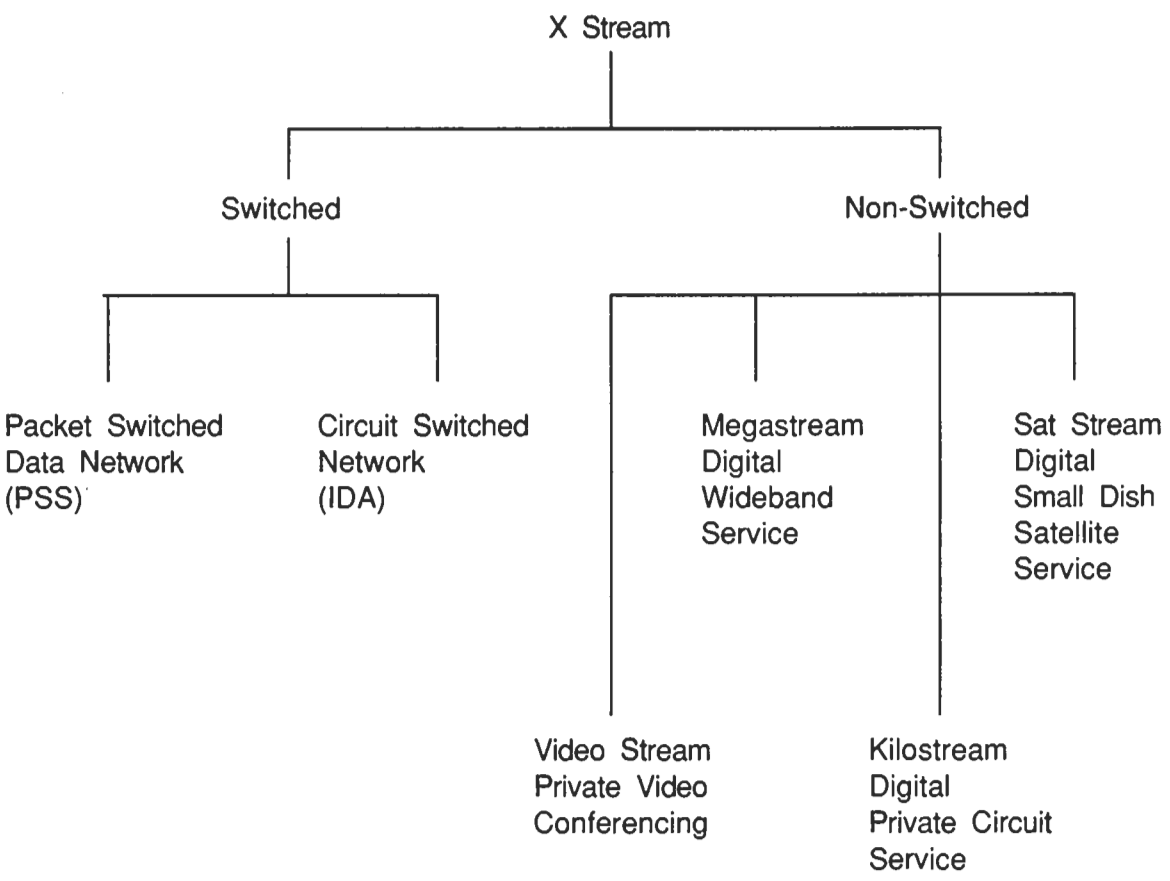

X-STREAM SERVICES

FIG 9C.1

3. Switch Stream - switched Digital Services are of two types:  
(1) Packet Switch Stream (PSS) used for non-voice communications using packet switching techniques (X25).

(2) Integrated Digital Access (IDA) - a circuit switched system for both voice and non voice communications. Uses System X exchanges and digital transmission paths.

4. Video Stream provides a video conferencing facility. Video conference studios fitted with digital video equipment are provided in large business communities. Access to the service may be from the central studios or Video Stream links provided directly between customers premises.

5. Megastream provides a high capacity digital service at bit rates of 2.048 M bit/s and above, suitable for large corporate networks or as a high capacity point to point digital link. The 2 M bit/s systems may be used with multiplexers to provide voice or lower bit rate data circuits.

6. Sat Stream offers a limited international service. Digital links are available at multiples of 64 k bit/s. Access to satellites is via small dish earth terminals at customer's premises or in business centres for shared use. Though mainly an international service it may be used for temporary or emergency services.

7. Kilostream is the digital Private Circuit Service offering synchronous full duplex data circuits at predetermined bit rates.

8. Of these, Kilostream and Megastream services are suitable for use in the NSTN.

## KILOSTREAM

9. This offers five user bit rates of 2400, 4800, 9600, 48 k and 64 k bit/s, although, by use of multiplexers, these bit rates may be subdivided to form a large number of lower bit rate channels.

10. The network offers synchronous operation of data circuits using interfaces conforming to CCITT recommendations X21 (leased line) at all five bit rates, X21 bis (V24) at 2400, 4800 and 9600 bit/s or X21 bis (V35) at 48 k bit/s.

11. Due to the service's built in diagnostic capacity and short installation time it offers customers an alternative to the method of providing data communications via the analogue network.

12. The general configuration of the network to support Kilostream is shown in Fig 9C.2. It shows multiplexing and cross connect sites interconnected via 2 M bit/s bearers. Every multiplexing site is connected directly to a cross connect site.

13. Customer access is via either the multiplexing site or the cross connect site which are provided in telephone exchanges. For individual customers who have a high demand for services, direct access can be provided by locating the multiplex equipment within the customer premises and having a 2 M bit/s path to the cross connect site.

14. Every Kilostream circuit is routed via one or more cross connect sites where flexibility of routing can be achieved by utilising channels on the 2 M bit/s system.

15. Within the customer's premises, their Data Terminal Equipment (DTE) will be connected to the Data Circuit-Terminating Equipment (DCE) otherwise known as the Network Terminating Unit (NTU) and will operate at one of the five bit rates provided.

16. Multiplexing Sites. Located in telephone exchanges, these provide access to the network for customers in the exchange area.

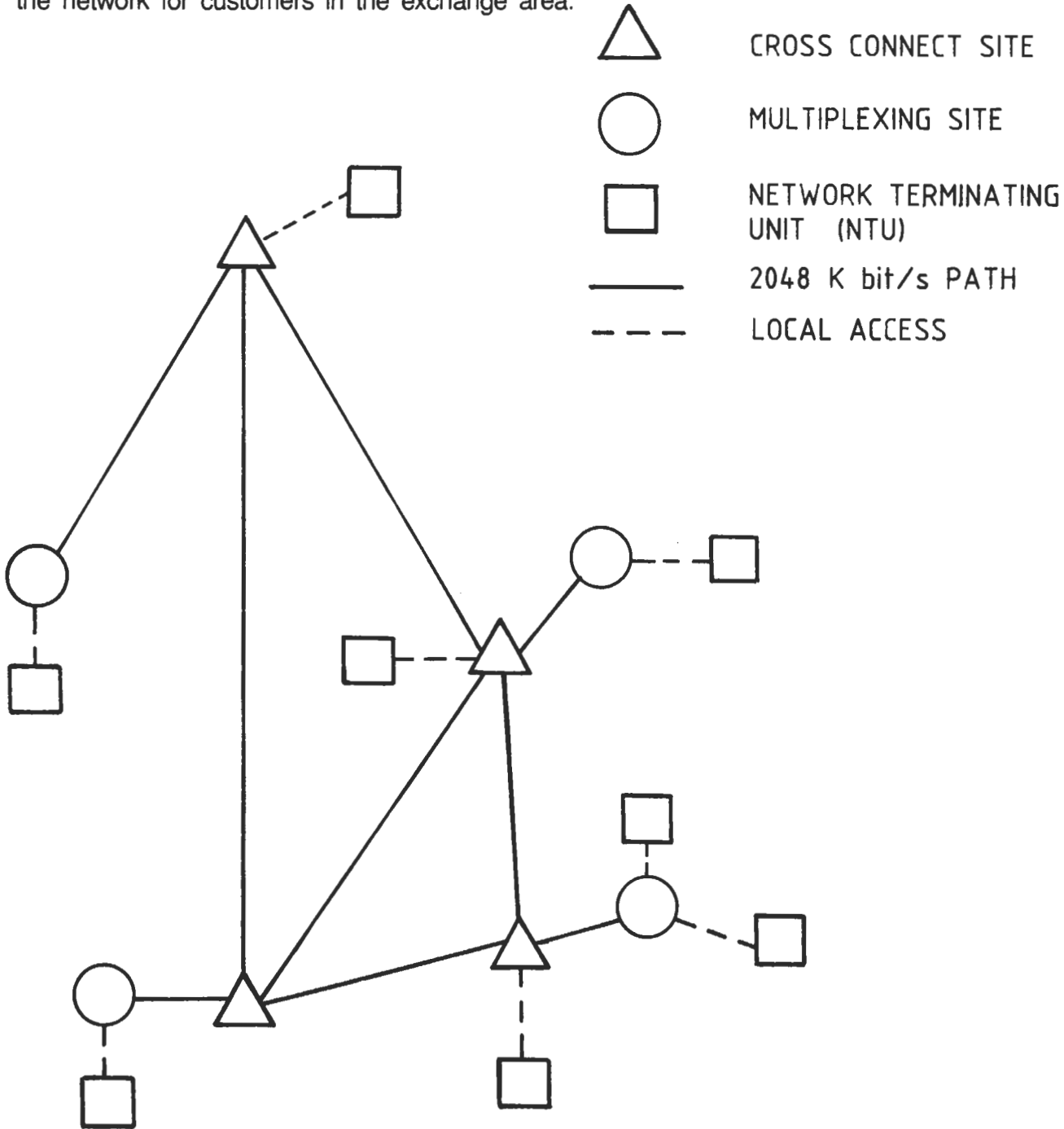

FIG 9C.2 KILO STREAM NETWORK CONFIGURATION

17. The multiplexer systems on the links to cross connect sites is a version of the 32 time slot PCM multiplexer. It provides for  $31 \times 64$  k bit/s digital data circuits, voice circuits not normally being provided.

18. Cross Connect Sites. These sites are the hubs of the network, providing the following facilities:

- (1) Interconnection of data circuits.
- (2) Local access to customers within the local exchange area.
- (3) Multiplexers and 2 M bit/s systems to all multiplexing sites within its geographical catchment area.
- (4) Multiplexers and 2 M bit/s systems to other cross connect sites.
- (5) Network synchronisation.
- (6) Circuit diagnostic and maintenance facilities.

19. Multiplexers used to terminate links to multiplexing sites and other cross connect sites are identical to those fitted at multiplexing sites.

20. Each Cross Connect site receives synchronising information from a national reference source. Multiple timing outputs are fed to all multiplexers and local access equipment at the Cross Connect site to ensure that every line system, multiplexer and tributary are operating at exactly the same bit rate.

21. The diagnostic and maintenance facilities allow alarm information detected from equipment on site and at the local multiplexing sites to be displayed.

22. This provides a measure of service monitoring of individual data circuits allowing rapid attention to faults in advance of customers complaints.

Note: BT has two centralised fault reporting centres at London and Manchester to which all Cross Connect sites are linked.

23. Tariffs. Tariffs for Kilostream digital private circuits include provision of an NTU at each end of the circuit, thus allowing customers to connect their own data transmission equipment.

24. Rental charges are payable annually in advance, exclusive of VAT. Charges are a combination of a fixed charge together with a charge based on the straight line distance between the two Kilostream serving exchanges.

### MEGASTREAM

25. This is the customer based private digital network service available to those who have need of a large traffic carrying capacity.

26. The bit rates available conform to the CCITT recommendations for digital hierarchy and are based on the 2.048 M bit/s building block (Fig 9C.3).

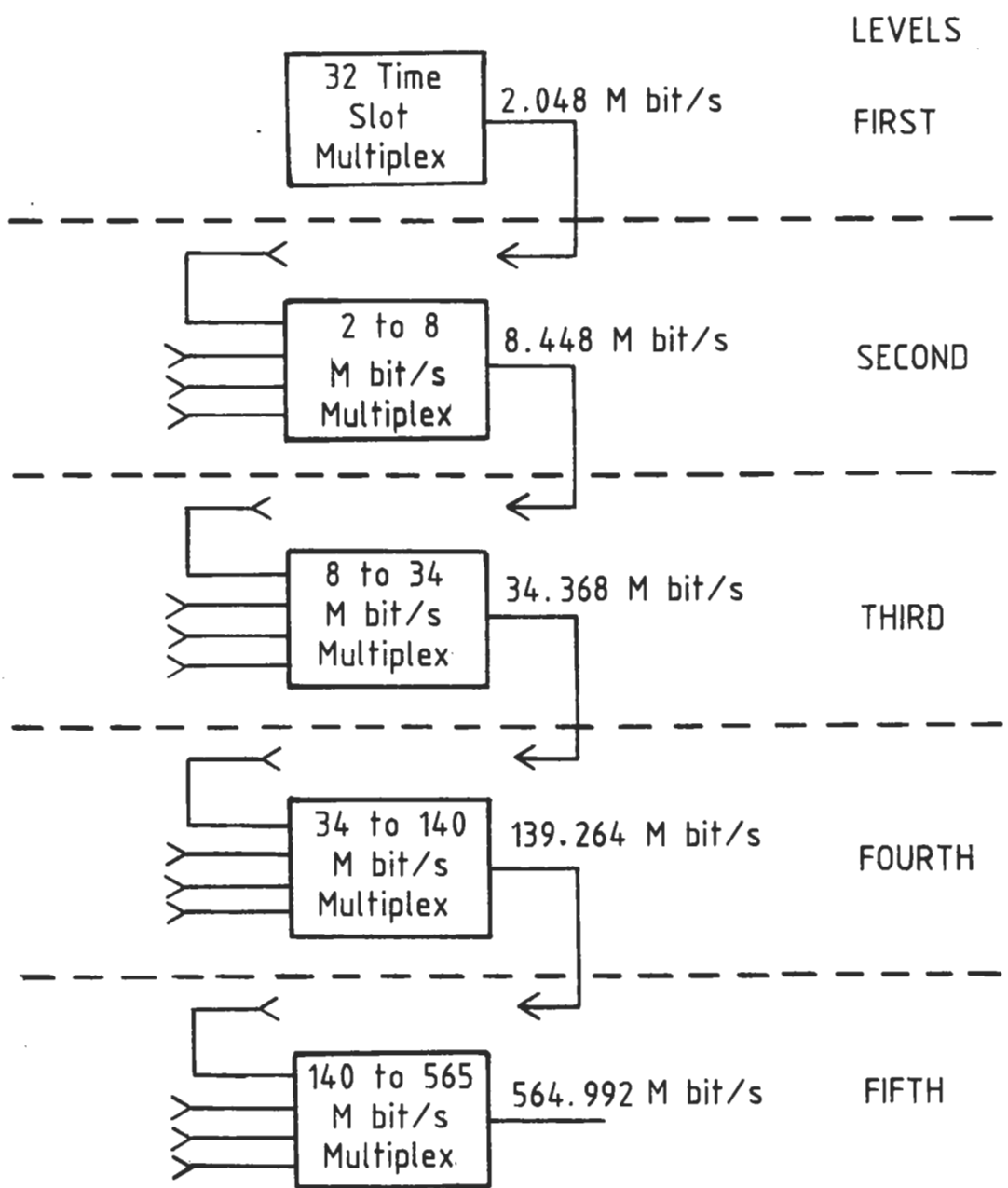

FIG 9C.3 HIGHER ORDER DIGITAL HIERARCHY

27. The two most usable rates are at 2.048 M bit/s and 8.448 M bit/s though rates of 34 and 140 M bit/s can be provided. By use of additional equipment a number of lower data rate and speech circuits may be multiplexed together to match the basic digital system.

28. Megastream 2 is the basic circuit to which enhanced facilities may be added. It provides customers with an interface at 2 M bit/s conforming to CCITT recommendation G703 to which they can connect their own equipment. Typical uses are:

- (1) Direct high speed data between computers.

(2) Direct connection to digital PABXs.

(3) Video conferencing.

29. For customers whose Megastream 2 service needs to be routed via the BT main network then it comes part of a higher order system. For the section between the customer premises and the access point on the BT network, a dedicated system is provided.

30. The existing local cables are unsuitable for the 2 M bit/s signal therefore transverse screen cables or microwave radio systems must be used for that dedicated system.

31. The transverse screen cable contains two groups of cable pairs separated by a metallic screen. Each group of cable pairs carries the digital signals in one direction of transmission and the metallic screen provides an electromagnetic barrier between them to reduce interference and cross talk (Fig 9C.4).

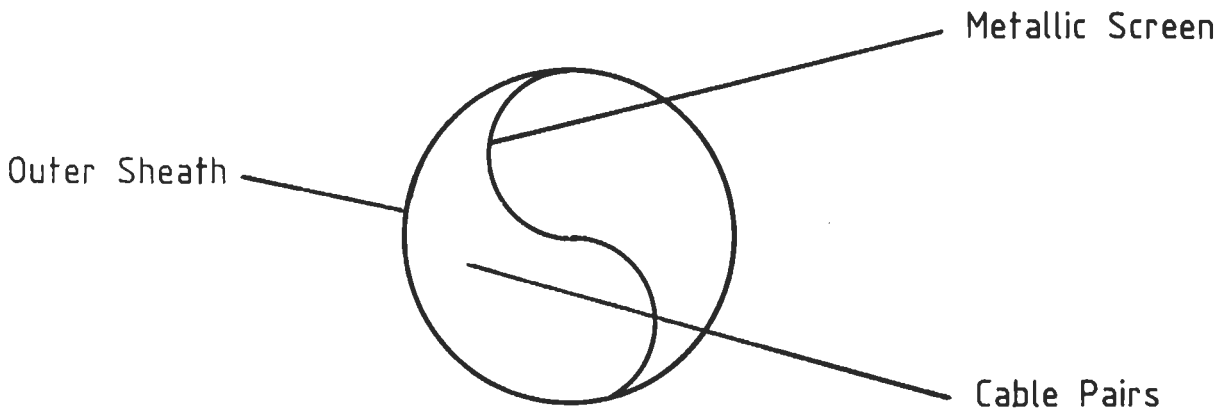

FIG 9C.4 TRANSVERSE SCREEN CABLES

32. To counteract the distortion experienced by the digital signals in their passage through the cable pairs, regenerators are inserted in the line at intervals of approximately 2 km.

33. When the service is provided on transverse screened cable, the Line Terminating Equipment (LTE) does not require external power, taking power for regenerators and alarm circuits from the incoming line.

34. Multiplexers. Since Megastream is a high bit rate transport system, the bit rates produced may be of little practical use, therefore multiplexers will be required to provide more useable rates. A range of multiplexers is available to be configured to meet the needs of the customer. Typical multiplexer facilities are:

(1) Voice channels using various encoding techniques.

(2) Data channels with various interface standards and bit rates.

(3) Network management.

(4) Synchronisation.

35. Under some circumstances, multiplexers are not required eg when direct connection is made to a digital PBX or Video Conferencing equipment is being used. In such cases the LTE must be situated adjacent to the terminal equipment.

36. The interface conforms to CCITT recommendation G703 which states:

(1) The bit rate shall be 2.048 M bit/s  $\pm$  50 ppm.

(2) Interface code will be High Density Bipolar 3.

(3) Maximum pulse voltage will be +2.37 V to -2.37 V.

(4) Impedance will be 75  $\Omega$  unbalanced.

37. Megastream 8, capacity 8 M bit/s, is provided for customers who have need of its very large digital capacity and is supplied on Optical Fibre cables. For customers who do not require the full 8 M bit/s capacity, equipment is provided to sub-divide the channel capacity into four sub-systems at 2 M bits/s each.

38. Synchronisation. As Megastream is just a method of getting a large number of bit/s between two points, it has no synchronisation built in. Since the digital signals are produced by the terminal equipment, it is from here that any required synchronisation is produced.

39. Tariffs. Megastream 2 provides 2,048 M bit/s data rate between customers premises. The tariff covers provision of a digital circuit between two customer network interfaces including the line and terminating units.

40. The tariff consists of an initial Connection Charge and Annual Rental. The tariff is based on the aggregate charge for 'Local Ends' and 'Main Link'.

41. The Local End charge is calculated on a straight line distance between customers premises at each end of the circuit and the nearest exchange equipped with digital plant.

42. The Main Link charge is calculated on a straight line distance between the two equipped exchanges.

43. Additional charges will be raised if new ducting is provided and for special customer requirements, eg added security, separately routed circuits or for the provision of service in advance of planned digital coverage.

## MOD(N) DIGITAL NETWORK

### (A MEGASTREAM NETWORK PROVIDED BY DNST)

The MOD(N) Digital Network is installed using 2 Mbps bearers leased from BT, interconnecting DATEL DM 7700 series multiplexors.

The network comprises 16 sites interconnected as in Fig 9D.1. A number of these sites have a cross connect capability allowing the patching of individual channels across multiplexors to achieve a network giving flexibility on system failures, while the remainder are connected as terminal only sites presenting 64 Kbps channels to the user.

The 2 Mbps MEGASTREAM bearer conforms to the CCITT standard frame structure containing  $32 \times 64$  Kbps channels of which 30 are available for customer use, the remaining two being required for frame and multiframe alignment and for signalling.

When a circuit is cross connected between sites using more than one MEGASTREAM bearer, the circuit is patched in the 4-wire mode (G703) to enable timing information to be passed. The channels are extended to Krone connection strips where patching is effected.

### System Alignment/Signalling in the MEGASTREAM Environment

One sequence of 32 time slots occupying  $125 \mu\text{s}$  is a Frame. The bit pattern in time slot 0 of each frame is used for alignment and is known as the Frame Alignment Word.

A sequence of 16 frames, occupying a 2 ms period, is a multiframe. This multiframe is split into odd and even frames and the alignment pattern in time slot 0 is different for odd and even frames.

Time slot 16 in the frame and multiframe structure is used for signalling. This may be channel associated signalling whereby each of the 30 channels is allocated a number of bits within the time slots - 16 of the multiframe; or Common Channel signalling where the 64 Kbps capacity of time slot 16 is made available to external equipment. This external equipment will produce a signal which may contain information relevant to the 30 channels using the multiplexor but also any additional circuits which may be using the PCM multiplexors associated with other systems.

### Line Coding

A purely binary digital coding is generally unsuitable for transmission over a line system because:



In addition, should there not be an odd number of  $\pm 1$  elements between successive violations, the first of four consecutive 0 levels is replaced by a 1 element (P1) alternating with the previous 1.

The polarity inversion of alternate 'marks' ensures that spurious signals are not present. By changing some 'spaces' to 'marks' ensures that adequate timing signals are present. The introduction of additional 'marks' increases the 'mark' density, hence the name High Density Bi-Polar 3.

### Node Equipment

Digital network processors from the CASE Series 7700 range are installed at the nodes. Those at Bureau West and Carpenter House are single trunk 7720 multiplexors; every other node is equipped with a multi trunk 7780 system. The 7720 may be upgraded to a 7780 if required.

NB. At present Bureau West and Carpenter House have no relay function, serving only a local network in each instance.

As an integrated network processor, the 7780 allows the integration of voice, data, facsimile and video into a single common network to allow total flexibility in the management of the available resources.

Each node may be equipped to handle up to  $10 \times 2$  Mbps trunks, with a variety of voice and data interfaces available to provide up to 600 ports per node.

### Timing

Series 7700 equipment provides Dynamic Clock timing to eliminate the restrictions of frequency locked systems. Each channel is capable of independently adjusting its timing to match that of the incoming data channel thus allowing for differing clock speeds in the network.

### Network Configuration and Control

Network control is performed by distributed intelligence. Software at each node ensures that, in the case of a trunk or nodal failure, the rest of the network will continue normal operation. That is, it is not necessary to refer back to a central Network Management Centre before re-routing traffic. Each time slot is routed independently as it is initiated, and maintains this routing for the duration of the time it is in service unless there is a failure.

Although the networking intelligence is distributed across all the nodes, the entire network may be managed from a single point. This facility is provided by the Network Management System which utilises an IBM PC PS2/50. From here all configuration, diagnostic and administrative control can be exercised, but the PC is not responsible for any routing decisions and can therefore be removed without affecting network operation.

