

## COMMUNICATIONS RECEIVERS

Background noise is always present in a receiver system, even if no signal is being received.

This noise is of two main types.

### (a) External Noise

- (1) Man made or contact noise from machines, switches, lamps etc.
- (2) Atmospheric noise or static, mostly from thunderstorms.
- (3) Cosmic noise or radiations from outer space.

### (b) Internal Noise

- (1) Thermal agitation - due to random motion of the electrons in any conductor. There will be contributions from the aerial itself, the receiver input circuits and the first stage of the receiver.

The r.m.s. noise e.m.f.  $e = 2\sqrt{K.T.B.R.}$

where K is Boltzman's constant =  $1.374 \times 10^{-23}$  joules per  $^{\circ}\text{K}$

T is the temperature in  $^{\circ}\text{K}$

R is the resistive component of the circuit impedance

B is the bandwidth.

From this one point emerges clearly, the wider the bandwidth in use the more noise that must be tolerated.

- (2) All valves produce noise to add to the general set noise. This can be divided into several parts. Schott noise due to the random emission of electrons from the cathode. Partition noise to the random division of electrons between electrodes. This, in general, means that multielectrode valves such as frequency changers are noisy.

### Variation of noise with frequency

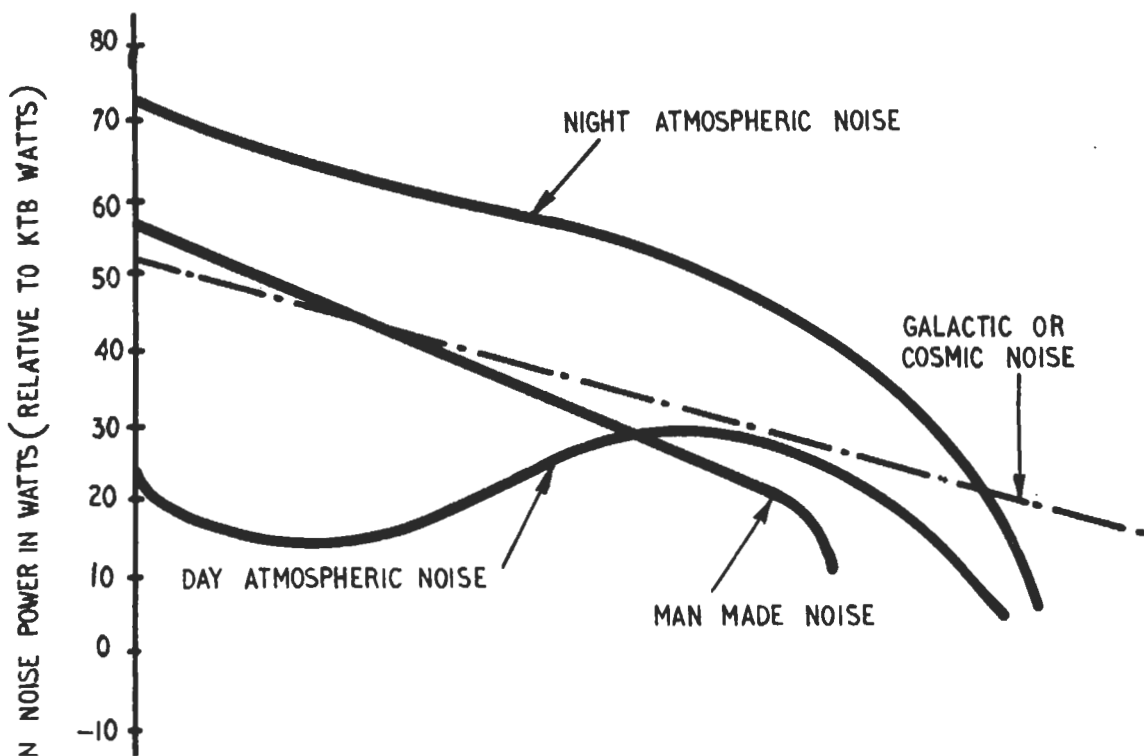

At the lower frequencies atmospheric noise predominates. Between 20 Mc/s and 100 Mc/s cosmic noise is the most significant. As the frequency increases above 100 Mc/s internal noise becomes much greater so that multielectrode valves become increasingly noisy and therefore useless at UHF's.

### Signal to Noise ratio

It is now necessary to define by how much the received signal must exceed the overall noise level. This criterion is a function of the receiver bandwidth, the type of intelligence imposed on the r.f. carrier and the quality of the service required.

Experience has shown that in order to achieve 90% intelligibility of sentences in a double sideband radio-telephone communication link using a 6 kc/s receiver bandwidth, an average signal to noise ratio of 14 dB is required. It has become common practice to accept this level as the standard reference and the following table lists the sig/noise ratios required for three other types of service, with respect to this reference level. The figures quoted have all been increased by 8 dBs to compensate for rapid fading (see chapter on propagation).

Type of Service	Conditions	B.W.	S/N ratio (dB)
d.s.b. Radio Telephony	Speech grade quality at 100% modulation 90% of the hour	6 kc/s	22 (i.e. 14 + 8) dB
s.s.b. Radio Telephony	Speech grade quality, carrier suppressed by 10 dBs 90% of the hour	3 kc/s	13 dB
Manual c.w.	15 words per min 90% of the hour	2 kc/s	8 dB
f.s.t.	150 words per min 850 c/s shift 99.9% of the hour	1.7 kc/s	19 dB

These figures indicate the S/N ratios that can be expected to give a satisfactory signal output from good equipment. However, as has been shown the receiver itself will provide some noise and it is necessary to measure how much noise the receiver produces by means of noise factor of the receiver.

To define noise factor N or F

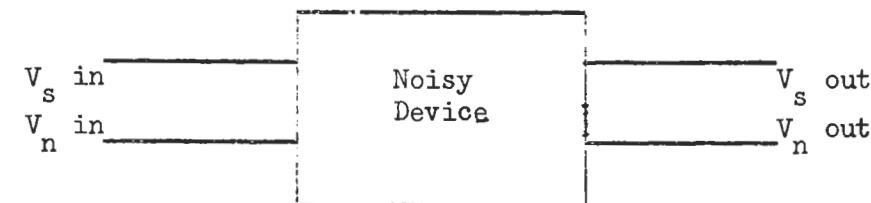

$$\frac{V_s \text{ in}^2}{V_n \text{ in}^2} = N \cdot \frac{V_s \text{ out}^2}{V_n \text{ out}^2}$$

$V_s$  = Signal Voltage  
 $V_n$  = Noise Voltage  
 $N$  = The Noise Factor

This definition of noise factor is of universal application and may be used for a single stage or a complete receiver. The definition is easy to understand, but the determination of the S/N ratios at the input and output may be difficult.

### Measurement

The actual measurement of noise factor, noise gain and signal to noise ratio is only applicable to a particular design of receiver. The method of measurement is always adequately covered in the makers handbooks.

### The receiver in a ship's environment

In general it is not practicable on a ship to find a sufficient number of sites to provide an aerial for each receiver, and a system of common aerial working is generally used. The general arrangement to be used in modern systems is shown in the diagram. The aerial is connected to up to a maximum of fourteen receivers in series by a coaxial cable earthed at its far end through its characteristic impedance.

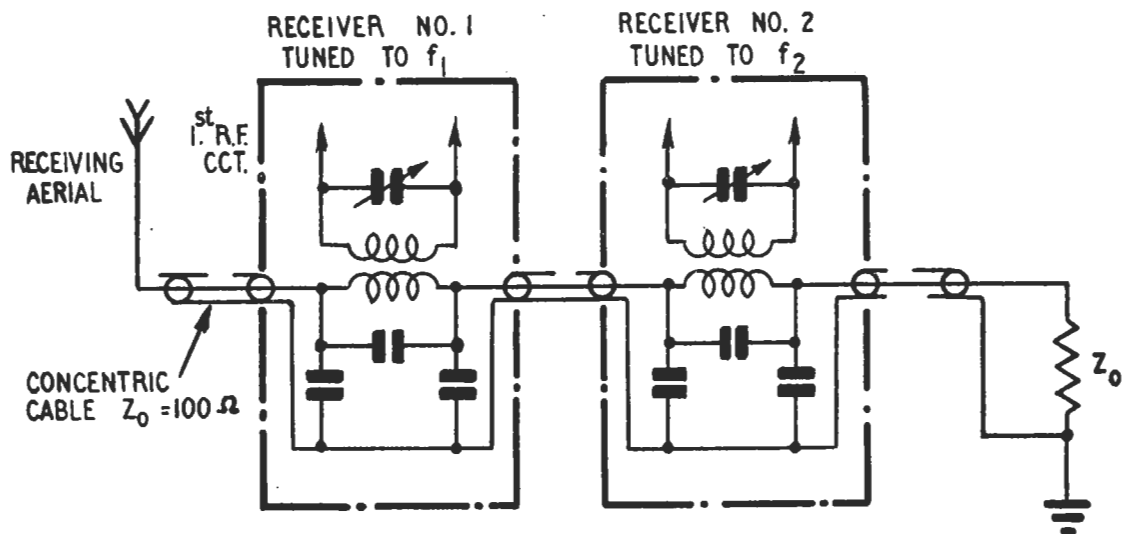

RECEIVER COMMON AERIAL WORKING

Diag. 9.3

In some cases it is an advantage to divide the receivers, fed from one aerial, into two groups, each group being concerned with signals in a given frequency band.

Rejection filters can be inserted in the aerial feeder lines before the receivers to reduce the voltages due to the ship's own transmissions. These are tuned to the frequency of the transmission and have an attenuation of the order of 40 dB at the tuned frequency and an insertion loss of not greater than 3 dB at frequencies 5% from the tuned frequency. The circuit of the rejection filter is as shown.

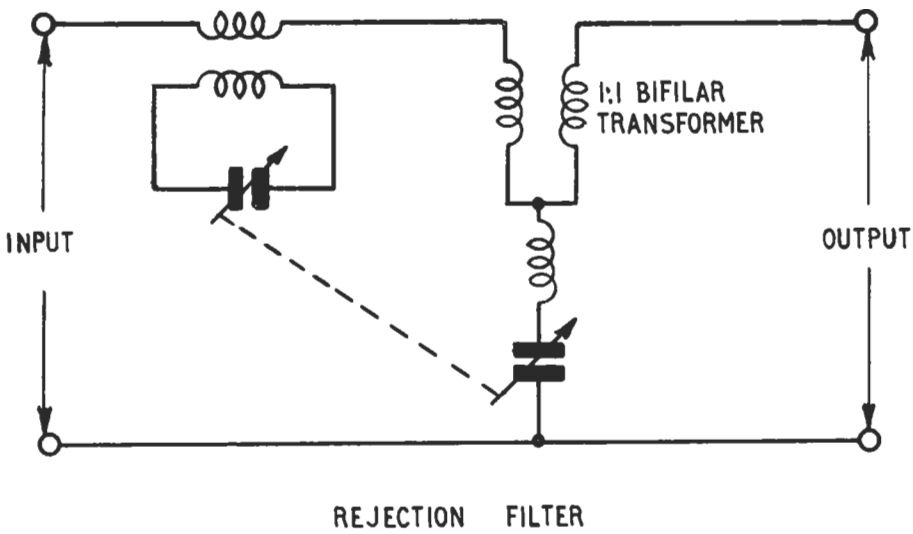

Diag. 9-4

### The Receiver

The receiver is required to select the wanted signal from the voltages delivered by the aerial and to amplify it to an adequate level to display the intelligence in some form or other.

The sensitivity of a receiver is usually defined as the minimum signal which will give a 10 dB ratio of signal plus noise to noise. This definition has a practical basis since it recognises that noise is the limiting factor in readability of the signal. The amplitude of the noise varies directly with the width of the band of frequencies which the receiver will amplify to an adequate level and consequently the selectivity or bandwidth of the receiver should ideally be restricted to that required to convey the intelligence.

The basic design of a receiver for s.s.b. is the same as for d.s.b. amplitude modulated signals and receivers for the HF band are invariably of the superheterodyne type. The receiver consists of three main sections, the r.f. section, the i.f. section and the a.f. section. However the absence of an r.f. carrier introduces two important differences. In the older generation of s.s.b. receivers the carrier was reinserted in the signal and the reconstituted signal detected in the normal manner. This local carrier had to be reinserted in the signal with the same relationship as regards frequency, with the sideband components as the initial carrier in the transmitter drive. The amount of frequency error that can be tolerated before intelligence becomes unreadable is of the order of 100 c/s.

Some modern receivers tend to favour a form of frequency translation, where the s.s.b. signal is translated down in frequency by a process of heterodyning so that the final product is the original a.f. signal. This final product is often produced in a circuit labelled a product detector.

Secondly the characteristics of the automatic gain control system must be somewhat different from that used in a receiver designed for d.s.b. amplitude modulated signals. For the latter the control voltage is obtained by rectifying the carrier signal. Since this carrier is relatively constant and does not vary in amplitude rapidly, the system can have a relatively long time constant. In a receiver for s.s.b. carrier suppressed signals, the control voltage is obtained by rectifying the sideband in which the amplitude varies rapidly and may fall to zero. Consequently, the rectifier supplying the a.x.c. voltage must be quick acting, i.e. have a short time constant for the

rise and a long time constant for the delay.

## Communications Receivers

Early s.s.b. systems that do not have their drives controlled by frequency standards and synthesisers, utilise a pilot carrier that is radiated well below the peak sideband power level.

This pilot carrier is used for Automatic Frequency Control of one of the receiver frequency-change oscillators and also for automatic control of the receiver gain. Further it may be used as the carrier source for the demodulators. When the pilot carrier is used in the demodulation process it must be reconditioned by filtering and limiting processes to make it substantially free from amplitude variations.

The diagram 9.5 shows an early independent sideband receiver. The aerial is fed to the receiver through a 75 ohm coaxial cable. The first unit is an r.f. attenuator, which enables the receiver to work at optimum input level. The next unit is a two stage signal frequency amplifier, the gain of which should be just enough to ensure that the signal level exceeds the noise of the first frequency changer. The selectivity of the signal frequency amplifier must be such as to give good image signal rejection. The receiver is a double superhet to ensure that second channel and adjacent channel interference are minimised. The second i.f. amplifier feeds the carrier and sideband filters. Two oscillators are shown, one being crystal controlled and in normal use, the other being a variable frequency oscillator. The first oscillator frequency is such that the first i.f. is 2600 kc/s. The use of crystal control to give high frequency stability is very important in view of the narrow passband of the carrier filter. The first i.f. amplifier has two stages of amplification. The frequency response of this amplifier should be flat over a band of at least 18 kc/s. This is necessary to cater for the two 6 kc/s sidebands and for the  $\pm 3$  kc/s required for the a.f.c.

The second frequency changer produces the second i.f. of 100 kc/s. The second oscillator is designed to give two frequencies 2500 kc/s and 2700 kc/s, either of these may be used at the second frequency change, in order to comply with the location of the A and B channels relative to the carrier, automatic frequency control is applied to the second oscillator by means of a motor-controlled tuning capacitor.

The output from the second frequency changer has a midband frequency of 100 kc/s and is divided into three parts.

1. The upper sideband 100 to 106 kc/s.
2. The lower sideband 94 to 100 kc/s.
3. The carrier of 100 kc/s.

The separation is carried out by the use of crystal filters, which in the region of 100 kc/s, can be made to have a very good performance, consistent with reasonable economy in design. The bandwidth of the carrier filter is a compromise between the conflicting requirements of the need for a very narrow band for selection of the pilot carrier from the other signals and noise; and the need for a bandwidth wide enough to facilitate tuning and to prevent loss of control by the a.f.c. circuit. The bandwidth of the carrier filter is approximately 80 c/s.

The frequency response of the sideband filters should be such that the overall frequency response is flat for audio signals from 200 c/s to 6000 c/s. The discrimination against frequencies in other sideband and unwanted signals must be very great. The carrier filter is followed by a linear two stage amplifier and the amplified carrier is then fed to the a.g.c. diode and to a limiter unit. The limiter unit provides a carrier of constant amplitude, called a reconditioned carrier, which is used for operating the a.f.c. system and is sometimes used in the demodulator.

The sideband paths function as follows. The output from the first sideband filter is taken through a single stage amplifier which is followed by an attenuator. This is provided to allow adjustment to be made to signal levels in accordance with the transmitter modulation depth, which is determined by the number of channels in use in each sideband. The attenuator is followed by the second sideband filter. The purpose of using two filters in cascade is as follows:-

The first filter, with a very sharp and steep cut off at 100 kc/s provides discrimination against the other sideband, while the other filter provides discrimination against the unwanted signals. Alternative second filters are provided, one with a passband of 6 kc/s and the other with a passband of 3 kc/s. The 3 kc/s filter may be brought into use when the receiver is handling multi-channel v.f. telegraphy which requires a narrower overall bandwidth, so that noise on the circuit can be effectively reduced.

The output from the second sideband filter passes to a two stage sideband amplifier, which provides the demodulator with the sideband voltage. The carrier voltage also is fed to the demodulator, either from the third oscillator, or in the form of a reconditioned carrier from the limiter. This voltage should be about ten times the value of the sideband input to the demodulator in order to keep distortion to a minimum.

The a.f. output of the demodulator passes through a two stage a.f. amplifier to a 600 ohm line, into which the normal output is 10 mW.

### Automatic Frequency Control

A.F.C. is achieved by adjusting the tuning capacitor of the second oscillator by means of a motor control. The motor is of the variable frequency type and is driven by a variable frequency four phase supply. The variable frequency supply for the motor is the difference frequency resulting from the combination of the reconditioned pilot carrier of 100 kc/s + a few c/s and the 100 kc/s from the crystal controlled third oscillator. As the pilot carrier varies above and below the third oscillator frequency, the difference frequency passes through zero and the order of the phases of the motor supply is reversed, hence the direction of rotation of the motor reverses. The speed of the motor is proportional to the difference frequency and becomes zero when the pilot carrier frequency is the same as that of the third oscillator.

### Automatic Gain Control

The a.g.c. of s.s.b. receivers is either derived from the pilot carrier, prior to reconditioning, or where the carrier is suppressed, from the sidebands. However, the sideband level varies with the modulation, and to help in overcoming this difficulty, the release time constant of the a.g.c. circuit must be longer than is normally used in a d.s.b. receiver. The discharge time constant is of the order of 10 seconds so as to prevent the output increasing during periods of no signal.

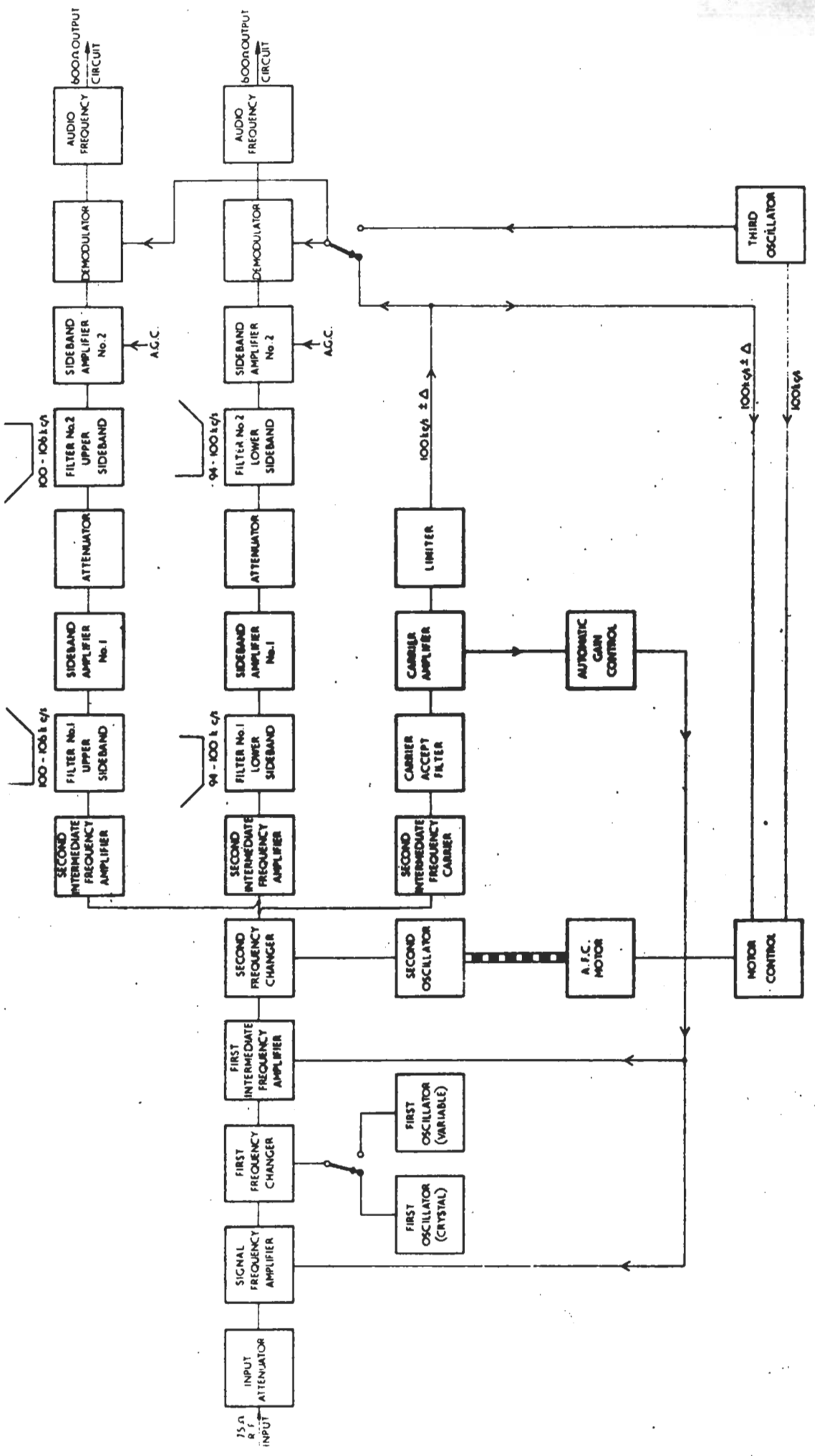

EARLY SINGLE SIDEBAND RECEIVER

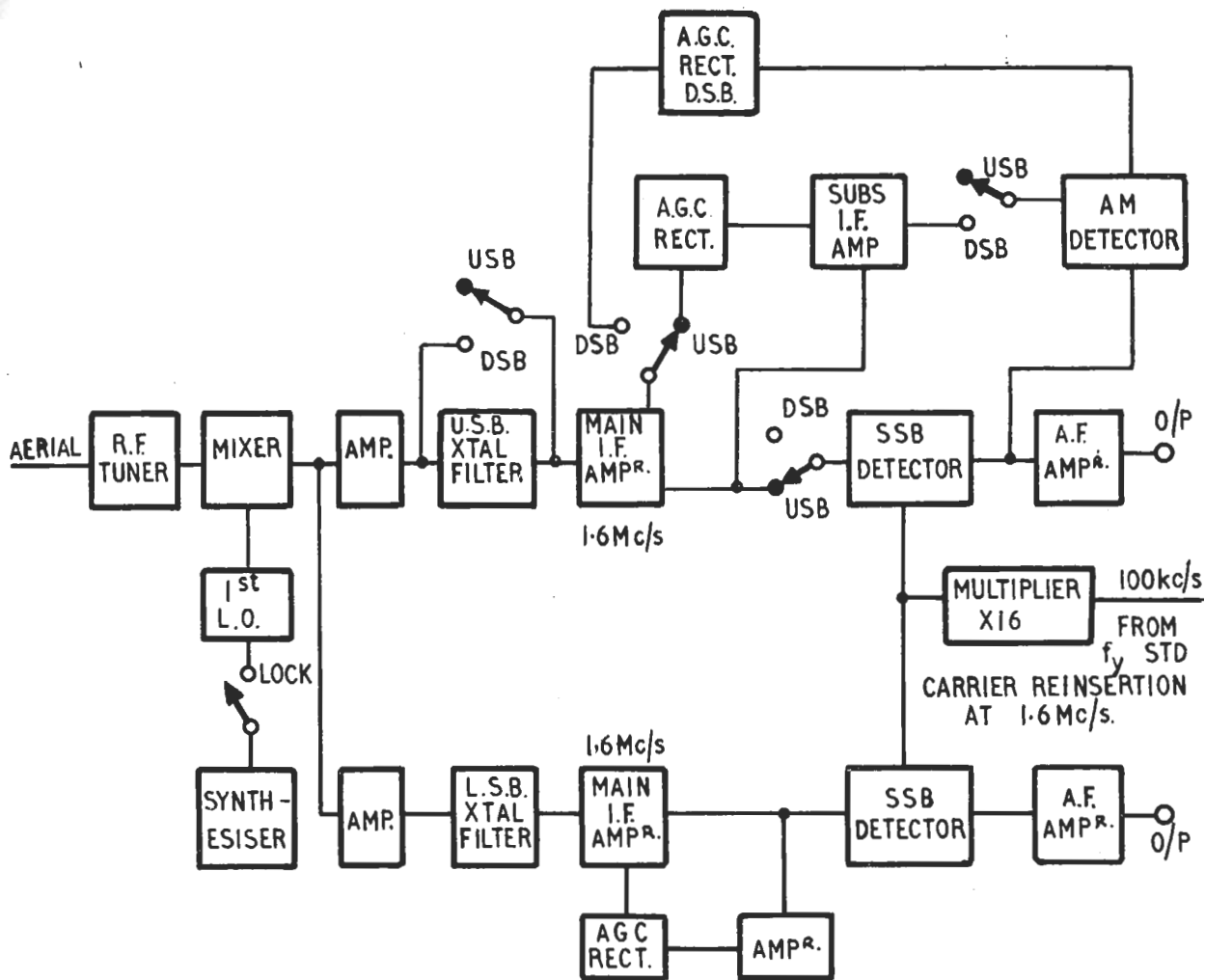

Diag. 9.6

The block diagram 9.6 shows the layout of the C.J.A. receiver. Here the carrier is reinserted at 1.6 Mc/s. The carrier voltage which is derived from the frequency standard is fed on to the screen grid of the product detector valve while the i.f. is fed on to the control grid. The two voltages are mixed in the valve or heterodyned, and the resulting a.f. voltage amplified in the a.f. amplifier.

The general layout of the receiver is that of a conventional superhet with one or two notable changes. The L.O. is controlled by the synthesiser (see chapter on synthesisers), and this increased stability means that these modern receivers can use several r.f. stages. In this receiver there are no less than 6 tuned circuits before the mixer stage and this would involve excessive attenuation, but for the insertion of r.f. amplifier stages. By using low noise triodes for the amplifier stages and the first mixer stage of the receiver, the signal levels required at the grids are kept low and they operate in a relatively linear mode.

In addition to the usual problems of interference from the image signal and cross modulation of a weak signal by a strong one, the large voltages from the ship's own transmission generate spurious signals in the receiver.

- (a) If two signals at unwanted frequencies  $f_1$  and  $f_2$  such that  $f_1 - f_2$  is equal to the i.f. reach the mixer, then an interfering signal will be present on all wanted signal frequencies, when at least one of the frequencies  $f_1$  or  $f_2$  is strong enough to be regarded as a local oscillator feeding the mixer.

- b) If two unwanted signals  $f_1$  and  $f_2$  such that  $2f_1 - f_2 = f_3$  where  $f_3$  is a wanted signal are present, an interfering signal will be produced at any non-linear element of the receiver such as an overloaded amplifier stage. Only the voltage at  $f_1$  need be large. This type of interference is known as "inter modulation" and is similar to the "rusty bolt" effect caused by accidental rectifiers present in the ship's structure, particularly rigging. Other intermodulation products such as  $f_1 - f_2 = f_3$  and  $3f_2 - 2f_1 = f_3$  could be troublesome but the measures introduced to prevent the first two types will also prevent these.

The interference will clearly be reduced by good design of aerial filters and the provision of good r.f. selectivity and designing all valve circuits to operate linearly.